

# Service Manual for Commercial Pearl Ice Machine

GEMU090



# GEMU090

## Installation and Use

### Introduction

---

This manual includes information for the installation, operation and maintenance of the GEMU090 residential ice machine.

The GEMU090 was developed to offer fans of Ice-O-Matic's Pearl Ice form the ability to have that ice in their homes. Previously pearl Ice was only available in commercial establishments, where it developed a strong following because of the chewable nature of the ice. This machine makes authentic pearl ice, using the same process as the larger commercial machines.

### Table of Contents

Product Description: . . . . .	Page 2
Cabinet Dimensions . . . . .	Page 3
Location Recommendations: . . . . .	Page 4
Familiarization . . . . .	Page 5
Door Swing . . . . .	Page 6
Plumbing - Pump Model . . . . .	Page 7
Plumbing: Gravity Drain Model . . . . .	Page 8
Electrical and Start Up . . . . .	Page 9
Use . . . . .	Page 10
Maintenance . . . . .	Page 11
How to remove scale from the ice making system. . . . .	Page 12

### **Outdoor Use Notice:**

Keep from freezing. Severe damage will occur to the unit if left in or operated in temperatures beyond the limits listed in this manual. That damage is NOT covered by warranty.

Keep dry. Do not locate in low lying areas where puddles will accumulate.

Provide Shade: Heat gain from the sun will reduce the unit's ability to make and store ice, and ultraviolet radiation from the sun can potentially damage the unit's plastic components.

Water Supply: Avoid a long run of hose or tubing exposed to the sun. Plastic water supply tubing should be rated for potable water and include UV protection. Copper tubing is recommended.

Back Flow Prevention: The unit includes back flow prevention, no additional check valve is required.

Drainage: Do Not drain into swimming pool or onto grounds.

# GEMU090

## Installation and Use

### Product Description:

---

This ice machine is designed to be used indoors, in a controlled environment or outdoors within certain limits.

The GEMU090 is made up of two major systems: the ice making system and the ice storage system. The ice making system is a continuous flow type ice machine, it makes ice when the ice level becomes low and stops when it is full.

The ice storage system is an insulated chest with a drain at the bottom for melting ice. It is not refrigerated, insuring that the bin contains fresh ice.

### Installation Information

Dimensions:

The cabinet is fourteen and seven eighths inches wide by thirty three and three eighths to thirty four and three eighths inches high.

### Utility and Operational Requirements

- The GEMU090 must be connected to a potable water supply.
- The water supply must have a conductivity of at least 10 microSiemens/cm.
- Minimum water pressure: 20 psi
- Maximum water pressure: 80 psi
- Minimum water temperature: 40 degrees F.
- Maximum water temperature: 90 degrees F.

It is designed to operate in wide range of air temperatures:

- Minimum air temperature: 50 degrees F.
- Maximum air temperature: 100 degrees F.

Although the machine will function within the listed ranges, it works best at water temperatures between 50 and 60 and air temperatures between 60 and 80.

---

Note: Ice making capacity goes down as the environmental temperatures go up, and will be severely reduced at temperatures over 90°F.

---

Operating a unit outside of the limits can cause problems that are not covered by the warranty and, if extreme, cause damage to the unit.

### Water Quality

The water to the machine must be potable, or fit for human consumption. Beyond that, water supplies vary in the degree of mineral content. As this ice machine makes ice, all the water that flows into the machine is changed into ice. That includes any minerals that might be in the water. However, during ice making some minerals will stick to the ice making components. The higher the mineral content, the more mineral build up will occur. Water filters are a partial help, as they will remove the suspended solids, but water treatment is needed for the dissolved solids, which are part of the water and cannot be filtered out.

RO Water

This machine can be supplied with Reverse Osmosis water, but the water conductivity must be no less than 10 microSiemens/cm. A reverse osmosis system should include post treatment or blending to satisfy the R.O. water's potential aggressiveness.

Deionized water is not recommended and could damage the machine.

Because water softeners exchange one mineral for another, softened water may not improve water conditions when used with ice machines

### Electrical power

The unit must be on its own 115 volt, 60 Hz, 15 amp circuit. It is equipped with a power cord and can be plugged into a nearby outlet. Extension cords are not allowed by most codes. Follow all applicable codes.

### Warranty Information

Warranty information is supplied on the inside front cover of this manual. Refer to it for coverage. In general, the warranty covers defects in materials or workmanship and does not cover corrections of installation errors or maintenance.

# GEMU090

## Installation and Use

### Cabinet Dimensions

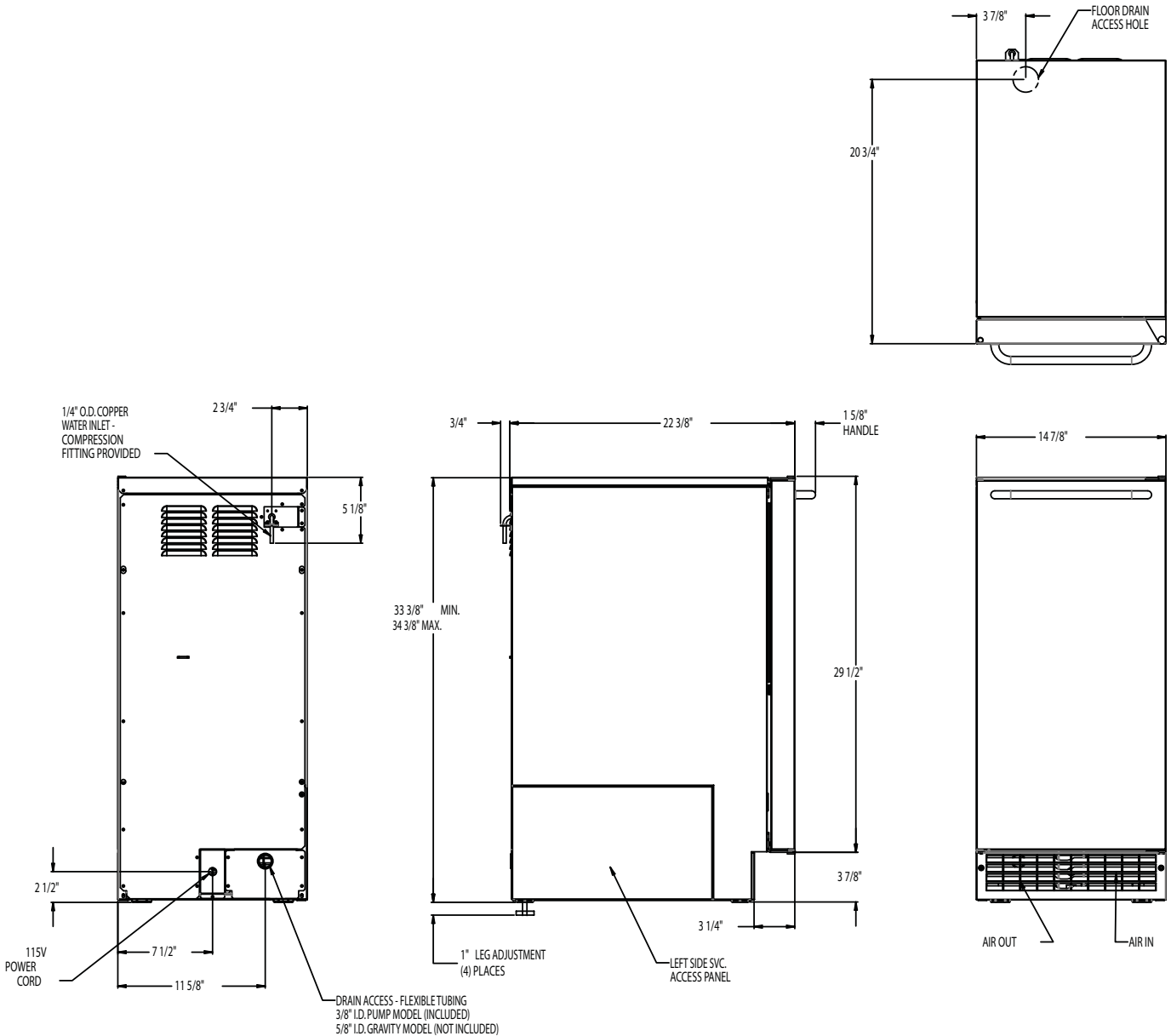

Ice-O-Matic Ice Systems are designed and manufactured with the highest regard for safety and performance. They meet or exceed the standards of agencies like ETL.

Ice-O-Matic assumes no liability or responsibility of any kind for products manufactured by Ice-O-Matic that have been altered in any way, including the use of any parts and/or other components not specifically approved by Ice-O-Matic.

Ice-O-Matic reserves the right to make design changes and/or improvements at any time. Specifications and designs are subject to change without notice.

# GEMU090

## Installation and Use

### Location Recommendations:

---

The machine can be built into a cabinet. It is an air cooled refrigeration system and so air flows in and out of it through the grill at the bottom front. The grill must not be blocked by any covering door or other obstruction.



The machine is a gravity drain model and must have a building drain connection below the level of the drain tube at the back of the cabinet. An optional field installed drain pump kit is available which can force drain water up a maximum of 10 feet, allowing it to be located where a gravity drain isn't available.

**Kickplate Extension:** In some situations the leg levelers will be extended enough to become visible. A kit to extend the kickplate over the legs is **KKPF**.

**Cabinet Stability:** In some free standing installations it may be prudent to add a bracket that secures the back of the cabinet to a wall. That kit number is **KATB**.

**Drain Conversion:** A gravity drain model can be converted to a drain pump model by installing a drain pump kit. The drain pump kit consists of a drain pump, wiring harness and associated tubing. The part number is **KPU090**.

### Installation Notes

**Built In Situations:** If a finished floor is to be installed in the area after the ice machine has been built in, shims the expected thickness of the floor should be installed under the unit to keep the machine level with the planned floor level.

---

**Note:** The water connection is at the back and adds a few inches to the cabinet depth. Minimum clearance is 0 in. at the top, 2 in. at the rear and 1/8 in. at each side.

---

**Installations on a slab:** Use a pump model and pump the water to the point of drainage. Pump models will pump 1 story (10 feet) high.

**Installations over a crawl space or basement:**

Either gravity drain or pump model units may be used, if there is not enough room behind the machine for a drain/waste receptacle, the drain will have to be below the floor.

---

**Note:** When installed in a corner, the door swing may be limited due to handle contact with the wall or cabinet face.

---

All models require a water supply. Water supplies vary in the degree of mineral content. High mineral content water will require more frequent maintenance. Water filtration may improve the taste of the ice as well as cut down on some of the mineral build up.

# GEMU090

## Installation and Use

### Familiarization

---

The control panel is visible when the door is opened. It has three indicator lights and two switches.

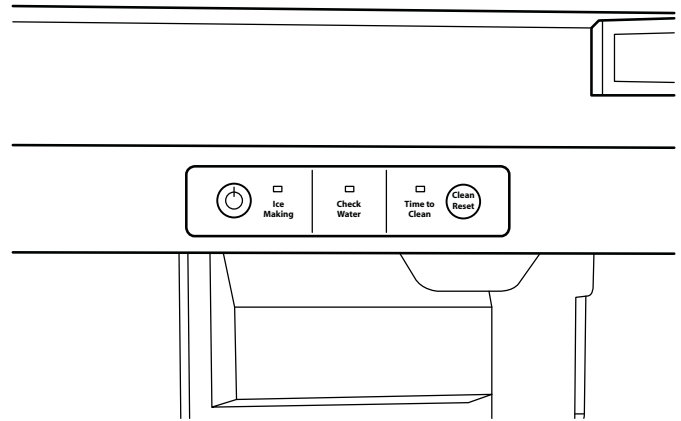

Control Panel

The model and serial number plate is located on the bottom of the control panel box. The Bin Light and Ice Level Sensor are also visible from that angle, as is the Ice Chute.

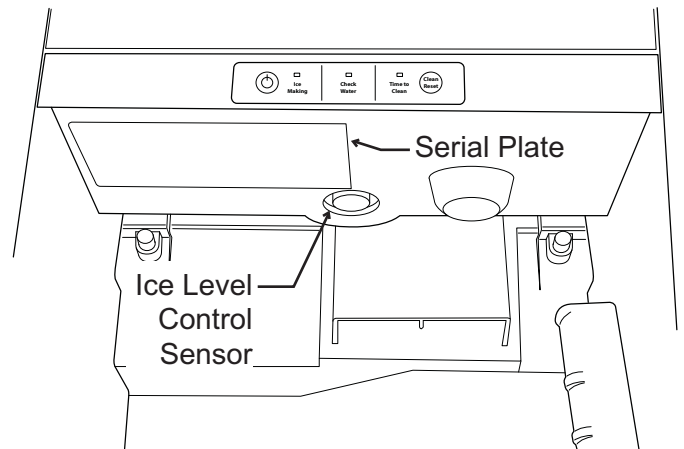

Serial Number Plate

The Scoop Holder is located on the right side of the ice storage bin. The normal ice level is about level with the scoop holder.



Scoop Holder

# GEMU090

## Installation and Use

### Door Swing

The door can be attached to open with hinges on the left or right. Retain all screws for re-use.

To change:

1. Remove top hinge pin from hinge.



2. Tilt top of door away from cabinet and lift door off bottom hinge.



3. Remove two screws and top hinge.
4. Remove plugs or screws from lower cabinet bracket
5. Attach top hinge to lower cabinet bracket using original screws.

6. Remove original bottom hinge.



7. Remove two plugs or screws from upper cabinet bracket.
8. Attach bottom hinge to upper cabinet bracket using the original screws.
9. Place the door on bottom hinge, tip up to slide under top hinge.
10. Insert hinge pin into top hinge and door.
11. Tighten hinge pin.
12. Replace screws or plugs into holes left by hinges.
13. Check action and swing of door.
13. Return kickplate and front service panel to their original positions and attach to the cabinet using the original screws.

# GEMU090

## Installation and Use

### Plumbing - Pump Model

#### Drains

There are two types of ice machine models, one that drains by gravity and one that has an internal drain pump.

#### Drain Pump Model drain installation

1. Locate the coil of 3/8" ID plastic drain tubing secured to the back of the unit.
2. Route the plastic drain tube from the back of the unit to the drain connection point.

The drain connection point can be as high as 10 feet above the ice machine. The drain pump includes a check valve to prevent re-pumping water in the drain hose.

---

**IMPORTANT NOTE:** Often an air gap is required by local codes between the ice maker drain tube and the drain receptacle.

---

#### Water Supply

The recommended water supply tubing is 1/4 inch OD copper. Stainless steel flex or reinforced PCV tube may also be used. Install an easily accessible shut-off valve between the supply and the unit. This shut-off valve should not be installed behind the unit.

The water connection is at the back of the cabinet. Connect using a compression fitting, one is supplied tied to the water inlet tube. When built in: Coil enough tubing behind the machine so it can be pushed into the cavity without kinking the tubing.

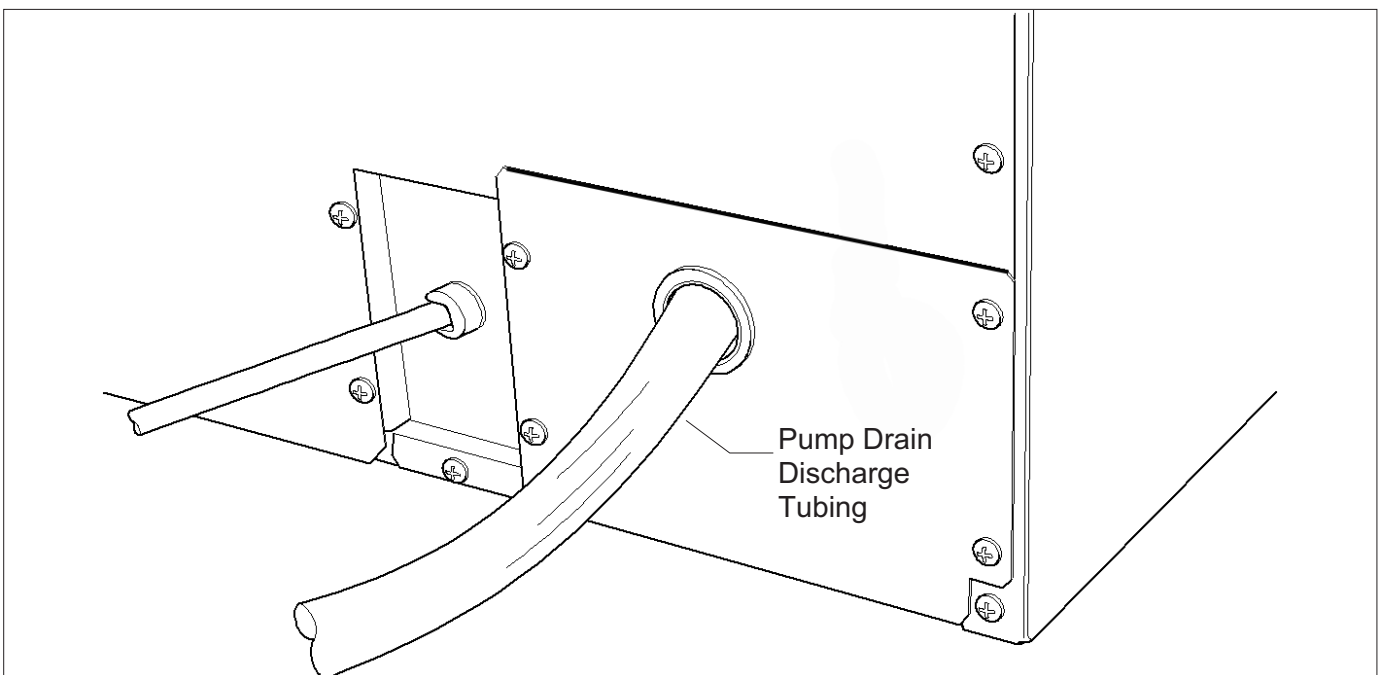
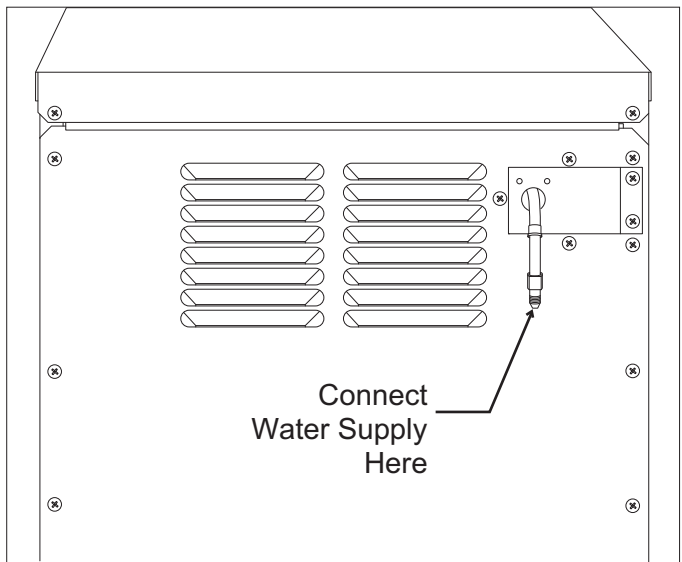



# GEMU090

## Installation and Use

### Plumbing: Gravity Drain Model

Caution: Restrictions in the drain system to the machine will cause water to back up into the ice storage bin and melt the ice. Gravity drain tubing must be vented, have no kinks and slope to the building drain. Air gaps are typically required by local code.

1. Place the ice machine in front of the installation opening. Adjust leveling legs to the approximate height.
2. Remove the upper back panel if needed for access to the drain fitting.

Note: If you are connecting a gravity drain model and the drain opening has been located in the floor under the base pan according to the pre install specifications, follow steps 3 through 5 to drain the unit through the base. If not, proceed to step 6b.

3. Remove the clamp and barbed elbow and take off the plastic cover in the base pan below the drain hose.
4. Connect a straight 5/8" barbed connector to the drain hose, securing with the clamp removed in step 3.
5. Cut an 8" piece of 5/8" ID X 7/8" OD tygon (clear plastic) tubing. Slide one end of the tube onto the outlet of the barbed connector and secure with a

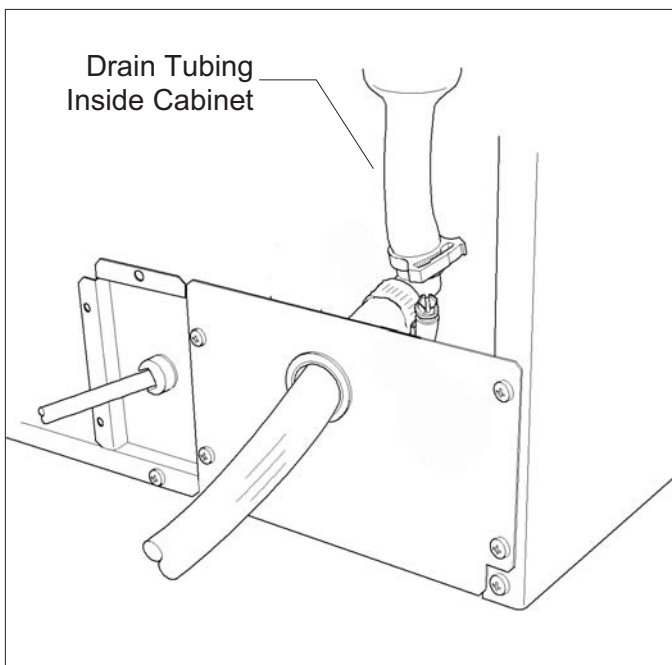

clamp. Leave the other end of the tube lying on the floor of the base pan until the unit is positioned over the floor drain.

6. Route the drain tube. Either a) Insert the drain tube through the base pan into the floor drain or b) Route the drain tube through the hole in the lower back panel and connect to barbed elbow and secure with a clamp.
7. Reinstall the upper back panel.

### Water Supply

The recommended water supply tubing is 1/4 inch OD copper. Stainless steel flex or reinforced PCV tube may also be used. Install an easily accessible shut-off valve between the supply and the unit. This shut-off valve should not be installed behind the

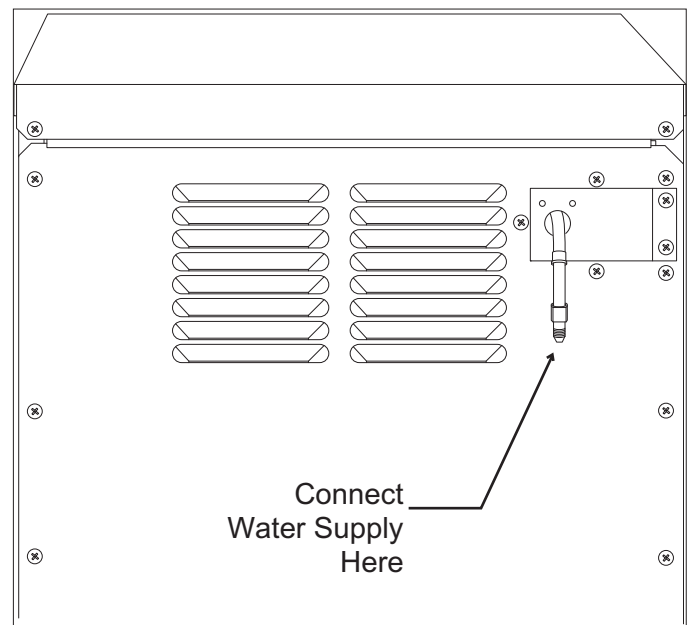

unit.

The water connection is at the back of the cabinet. Connect using a compression fitting, one is supplied tied to the water inlet tube.

When built in: Coil enough tubing behind the machine so it can be pushed into the cavity without kinking the tubing.

# GEMU090

## Installation and Use

### Electrical and Start Up

---

The ice machine is supplied with a power cord. Do not remove the grounding pin from the cord's plug. Do not use extension cords. Follow all codes.

Connect the machine to its own 115 volt, 15 amp circuit.

1. If the electrical outlet for the ice maker is behind the unit, plug in the unit.

2. Position the unit in the installation opening.

3. Turn on the water supply. Make sure that the ice maker is plugged in and the power is on.

4. Slide unit into installation opening, paying careful attention to water supply and drain connections. Do not kink!

5. Pour a couple of quarts of water into the ice storage bin; on drain pump equipped machines the drain pump should start and water should pump out. Check for leaks.

6. Replace the service access panel.

7. Level the unit as needed.

#### Installation check list:

1. Has the unit been connected to the proper water supply?

2. Has the water supply been checked for leaks?

3. Has the unit been connected to a drain?

4. Has the drain been tested for flow and leaks?

5. Has the unit been connected to the proper electrical supply?

6. Has the unit been leveled?

7. Have all packing materials been removed from the machine?

8. Has the door covering been installed?

#### Initial Start Up

1. Turn on the water supply and check for leaks.

2. Switch on the electrical power.

3. Push and release the On/Off switch to start the machine. The Ice Making light next to the On/Off switch will glow Green.

Warm air will flow out of the left front grill.

It will take about 10 minutes for the ice machine to begin dropping pearl ice into the storage bin. It is normal for that ice to melt and ice will continue to melt, but at a slower rate. It will take about 6 - 7 hours to fill up the ice storage bin. The bin holds about 20 lb of ice when full.

#### Ice level control

The ice level control for the GEMU090 is an ultrasonic sensor, located above the ice storage area. It is automatic and there is no adjustment to make. When ice melts or is used, and the ice level drops below a preset distance the control turns the ice making system back on. It makes ice until the preset level is reached. Placing your hand in the unit to remove ice does not affect the ice level.

# GEMU090

## Installation and Use

### Use

No special instructions are needed for use. Just take as much ice as you need, the machine will replace it. A scoop is provided, and it can be stored in the machine using the loop of tubing on the right side as a holder.

The machine can be shut off anytime by just pushing and releasing the On/Off button.

What shouldn't be done?

Never keep anything in the ice storage bin that is not ice. Objects like wine or beer bottles are not only unsanitary, but the labels can slip off and plug up the drain.

Never allow the machine to operate without regular cleaning. The machine will last longer if it is kept clean. Regular cleaning should happen at least once per year, and preferably twice. Some water conditions will dictate even more frequent cleaning of the ice making section, and some carpets or pets will dictate more frequent cleaning of the condenser.

---

Note: The Time to Clean light will switch ON after 6 months of use. It will remain ON until the ice making system is cleaned using the process on page 14.

---

### Noise:

The ice machine is designed for quiet operation, but will make some noise during the ice making cycle.

### Ice Making

During ice making, pearl ice will drop into the bin at an irregular rate; sometimes there will be little ice falling while at other times a group of pearls will fall. Some water drops may also come out with the ice. Both conditions are normal.

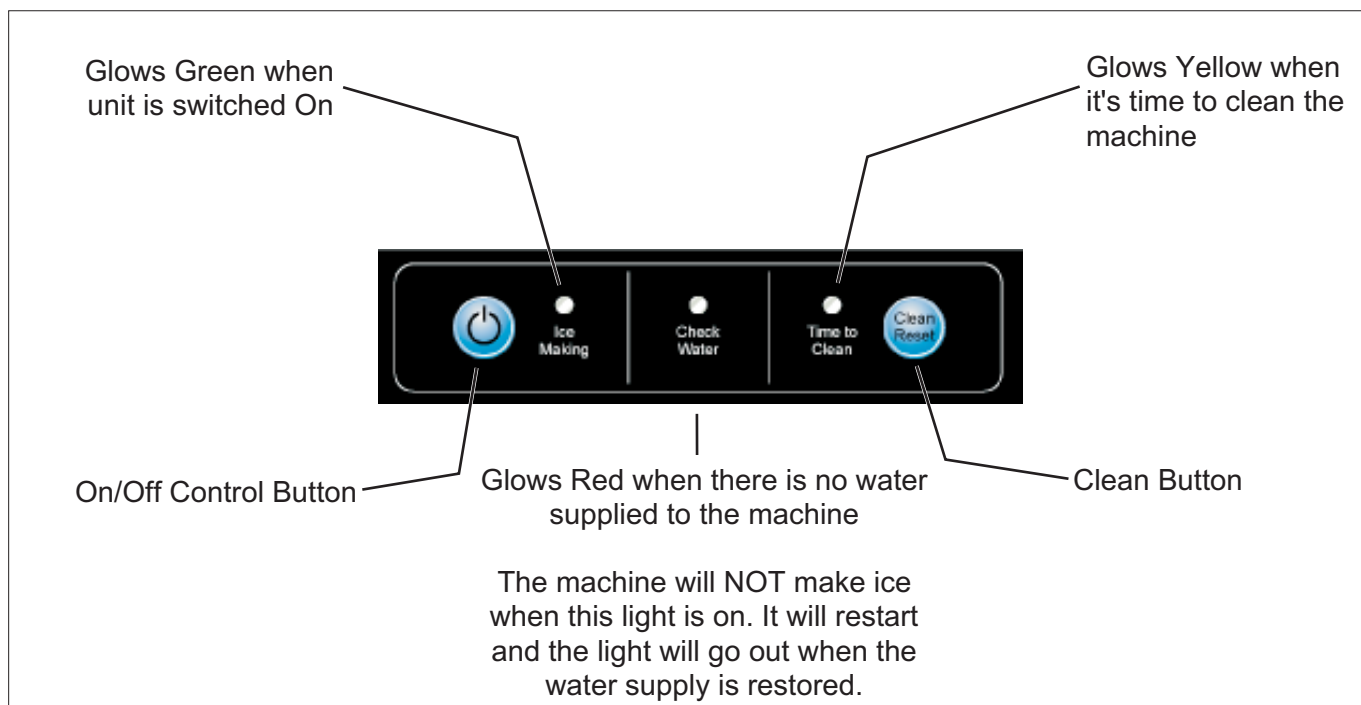

**Control Panel**

# GEMU090

## Installation and Use

### Maintenance

Ice-O-Matic **strongly recommends regular maintenance** of this ice machine. During normal operation mineral scale that is in the water supply will gradually build up on the ice making surfaces. That build up can cause excessive loading of the ice making system, which can cause premature failure. Regular removal of the mineral scale will lengthen the product's life.

Suggested maintenance schedule: every 6 months.

Type of maintenance: Scale removal, water seal check, water reservoir check, bin drain check, air cooled condenser cleaning and storage bin sanitation.

#### Condenser cleaning

The condenser is like the radiator on a car, it has fins and tubes that can become clogged with dirt and lint. To clean:

1. Remove the kickplate and front service panel.

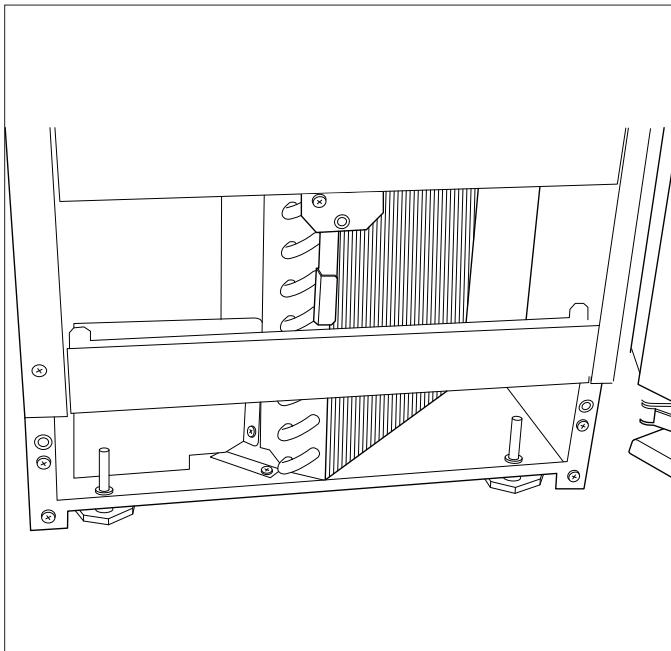

2. Locate the condenser surface.
3. Vacuum the surface, removing all dust and lint.

Caution: Do not dent the fins.

4. Return the kickplate and front service panel to their original positions. Fasten them to the cabinet using the original screws.

#### Winterizing

1. Clean the ice making system per the instructions in the Maintenance section.
2. Open the door and push and release the On/Off switch to turn the machine off.
3. Turn off the water supply.
4. Remove the back wall of the ice storage bin.
5. Remove drain plug and drain the water reservoir, return plug to its original position.
6. Drain pump models should have about 1/2 gallon of RV antifreeze (propylene glycol) poured into the ice storage bin drain.

---

Note: Automotive antifreeze must NOT be used.

---

7. Switch off and unplug the machine.

# GEMU090

## Installation and Use

### How to remove scale from the ice making system.

Cleaning this machine involves adding a solution of scale remover and water to the ice machine and continuing to add it as it makes ice. The scale remover must be diluted to the correct ratio. A squirt bottle will make adding the scale remover much easier when the unit is built in. If not built in, remove the top panel for reservoir access.

Recommended tools: Rubber gloves, squirt bottle & scale remover. Pre-Mixed 16 oz squirt bottle of scale remover is part number PMC090.

1. Scoop out and discard all of the ice.
2. Press and release the On/Off button.

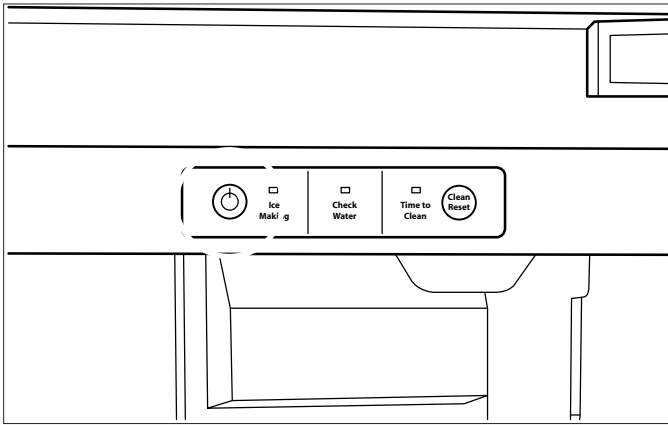

3. Open door and locate screws at upper back wall of bin. Remove the two screws.

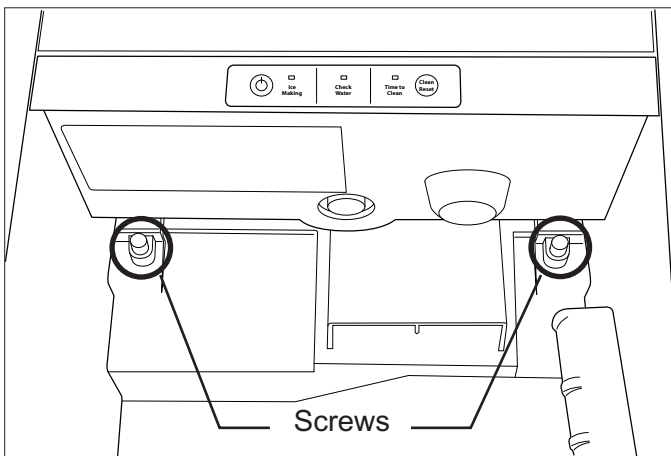

4. Remove the back wall of the bin by lowering it down past the scoop holder, feel free to rotate the scoop holder loop down to make more room.

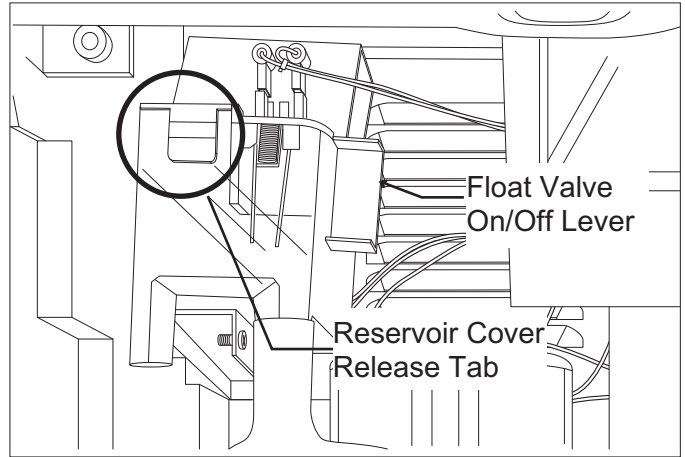

5. Push tab on front edge of reservoir cover and remove the cover. Note: Adjacent wires are low voltage and are not hazardous.

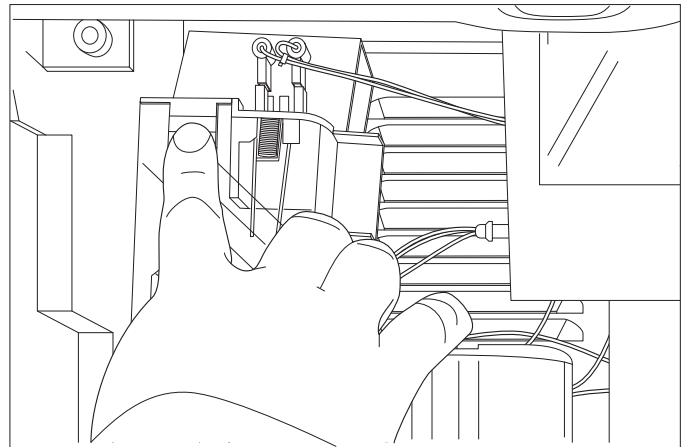

Push In Tab to Release Cover

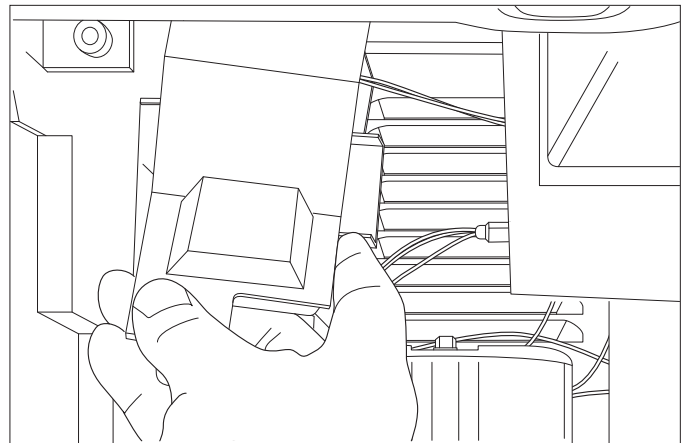

Lift Reservoir Cover to Remove

# GEMU090

## Installation and Use

6. Locate blue float valve on/off lever. Move lever up about half way to shut water off.

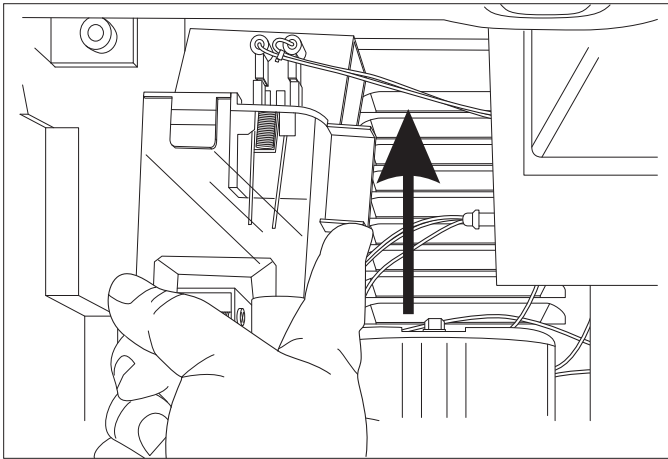

7. Locate drain plug and pull the drain plug out to drain the reservoir and evaporator. When draining is complete, return the plug to its original position.

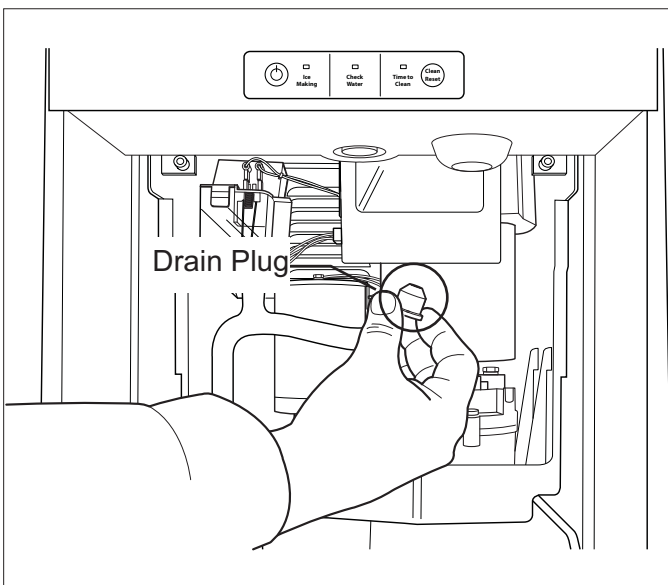
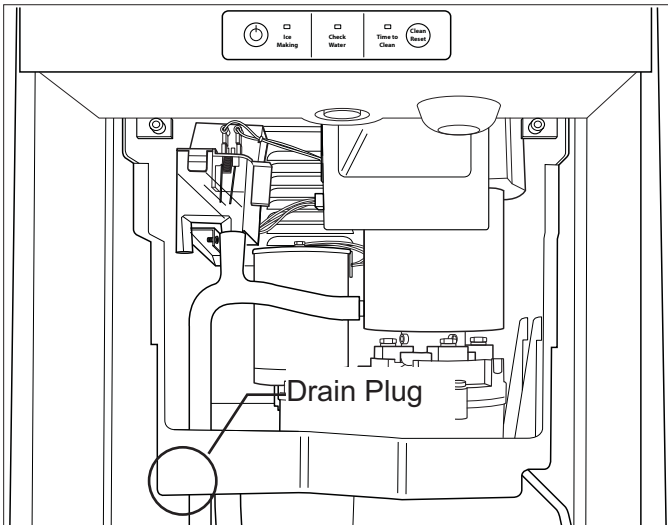

8. Obtain pre-mixed Ice-O-Matic Clear 1 Scale remover solution (with squirt bottle) or mix a solution of Clear 1 with water: 2.5 ounces of Clear 1 with 1 quart (32 oz) of warm water.

### **WARNING**



Ice machine scale remover contains acids. Acids can cause burns.

If concentrated cleaner comes in contact with skin, flush with water. If swallowed, do NOT induce vomiting. Give large amounts of water or milk. Call Physician immediately. Keep out of the reach of children.

Note: Take care not to spill any scale remover on any nearby surface. Immediately wipe any spill with baking soda and water.

9. Fill the 16 oz squirt bottle with the diluted scale remover.

10. Fill the reservoir with the scale remover solution using squirt bottle or other container. That will be about 8 ounces or half a squirt bottle.

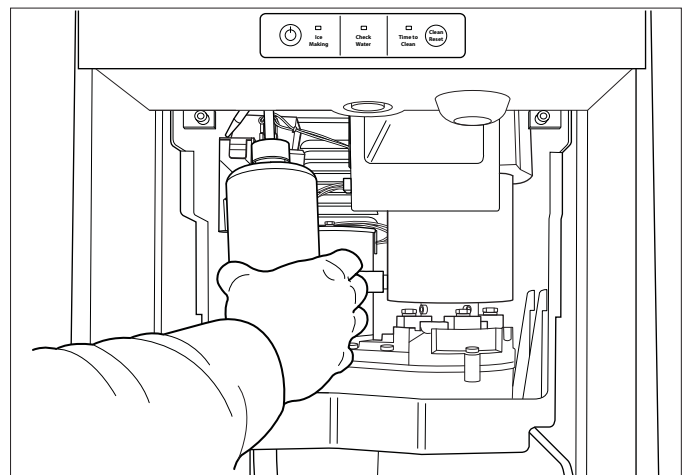

Fill Reservoir Using Squirt Bottle

# GEMU090

## Installation and Use

11. Press and HOLD both the Clean-Reset and On/Off buttons for 5 seconds. The Time to Clean light will blink on and off.

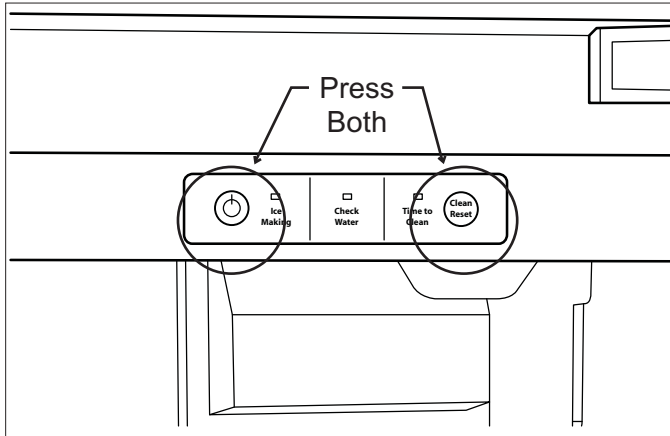

12. The auger motor alone will be operating for 10 minutes, after that the compressor will start and in about 5-8 minutes the machine will start to make ice. The Time to Clean light will now glow steady until the clean cycle is complete.

### Caution: Keep fingers away from moving parts.

12a. After ice making starts, continuously add scale remover solution to the reservoir to keep it about half full.

12b. When all 16 oz of the solution is used, move the float valve lever down to the On position.

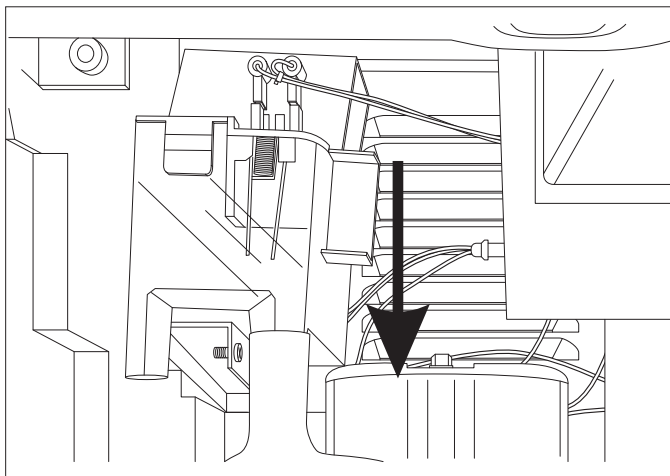

After 40 minutes the ice machine and all the control panel lights will shut off.

13. Pull the drain plug again to drain the system, then replace it.

13a: Optional - move float lever up to Off, add locally approved sanitizer\* to water system, then repeat step 13. Move the float lever down to On.

14. Return the reservoir cover to its original position.

15. Return the upper back wall of the bin to its original position and secure it with the original screws. Push in at bottom to snap it into place.

16. Pour a gallon of lukewarm (95°F. – 115°F.) water into the bin to flush out the drain and melt all ice that was made during the cleaning process. Be sure all ice is melted.

17. Clean the bin liner of mineral scale by using any left over scale remover solution to scrub the scale off of the liner. If none is left over, mix a solution of 2.5 ounces of Clear 1 Scale Remover and 1 quart of water.

18. Rinse the liner with hot water.

19. Sanitize the ice chute, ice sweep, breaker and bin interior using a locally approved sanitizer.\*

20. Push and release the On/Off button to restart ice making.

The ice scoop should be washed regularly, wash it just like any other food container.

\* A potential sanitizer may be made by mixing 1 ounce of liquid household bleach to 2 gallons of lukewarm (95°F. – 115°F) water.

### Other Maintenance

While cleaning the system with scale remover, check for water leaks at the bottom of the evaporator. If any are found, call for service.

---

Note: It is normal for some lime scale to form on the gear reducer cover. Wipe up any loose scale.

---

Check the top bearing.

The top bearing is non-metallic and requires no lubrication. However, it should be checked for wear occasionally. The top panel must be removed to access the bearing.

**GEMU090**  
**Service**  
**GEM090 service**

---

This section contains information for the service and repair of the GEMU090 ice machine.

Service Table of Contents

GEM090 service . . . . .	Page 1
Components: . . . . .	Page 2
Evaporator and Auger. . . . .	Page 3
Control System . . . . .	Page 4
Water System . . . . .	Page 5
Storage . . . . .	Page 6
Performance and Technical Specs . . . . .	Page 7
Electrical Sequence. . . . .	Page 8
Service Diagnosis . . . . .	Page 9
Service Diagnosis . . . . .	Page 10
Component Diagnostics. . . . .	Page 11
Ice Capacity . . . . .	Page 12
Removal and Replacement . . . . .	Page 13
GEMU090 Gearbox Access & Removal . . . . .	Page 14
Water Seal Replacement . . . . .	Page 16
Evaporator Replacement . . . . .	Page 18
Drain Pump (if equipped) . . . . .	Page 19
Compressor replacement. . . . .	Page 20
Bin and Cabinet . . . . .	Page 21



# GEMU090

## Service

### Components:

- Refrigeration system, including air cooled condenser, compressor, capillary tube and evaporator.
- Control system, including ice level sensor, water sensor, auger motor sensor, controller, control pad and transformer.
- Auger drive system, including auger motor, gear reducer and auger.
- Auger support system, including top bearing and water seal.
- Water system, including the float and reservoir.
- Storage system, including ice storage bin, drain and door.

During ice making the refrigeration system takes heat from the evaporator. The evaporator is a vertical refrigerated stainless steel tube containing water and a slowly rotating auger. When the water gets to the freezing point, ice begins to form. That ice is very soft and is pushed up the evaporator tube by the auger. As ice is made more warm water enters at the bottom. The soft, mushy ice is forced up to the top of the evaporator's tube where it is forced through nine tapered holes. As the ice is pushed through the holes excess water is squeezed out. The ice comes out of the holes shaped as a rod of ice. The rods of ice are broken off by being pushed against the tapered flange above the holes, forming the irregular lengths of pearl ice. The ice sweep, rotating with the auger, moves the ice to the ice chute where it falls by gravity into the storage bin.

The GEMU090 is a continuous flow ice machine. When the control system senses that the storage bin's ice level is low, it turns on the compressor, fan motor and auger drive motor.

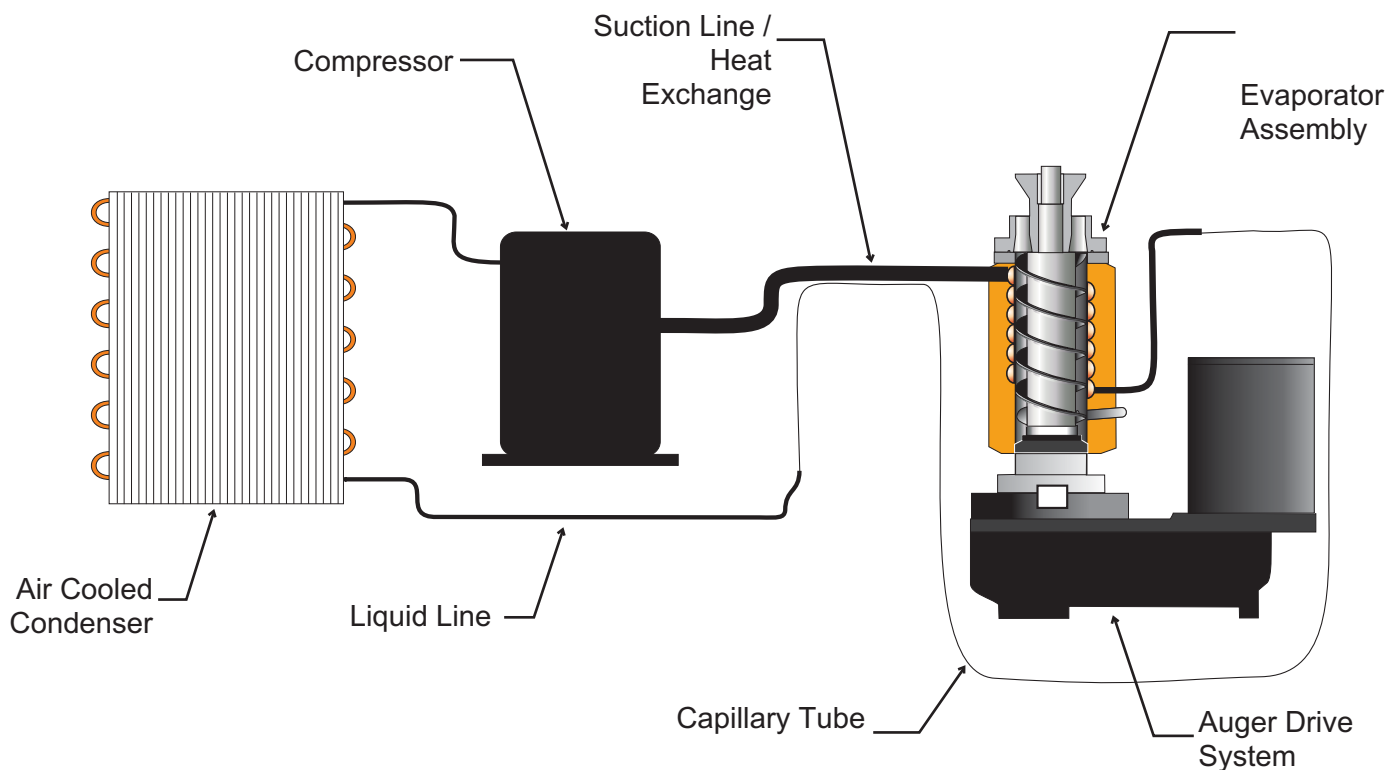

Refrigeration System Schematic

**GEMU090**  
**Service**  
**Evaporator and Auger**

---

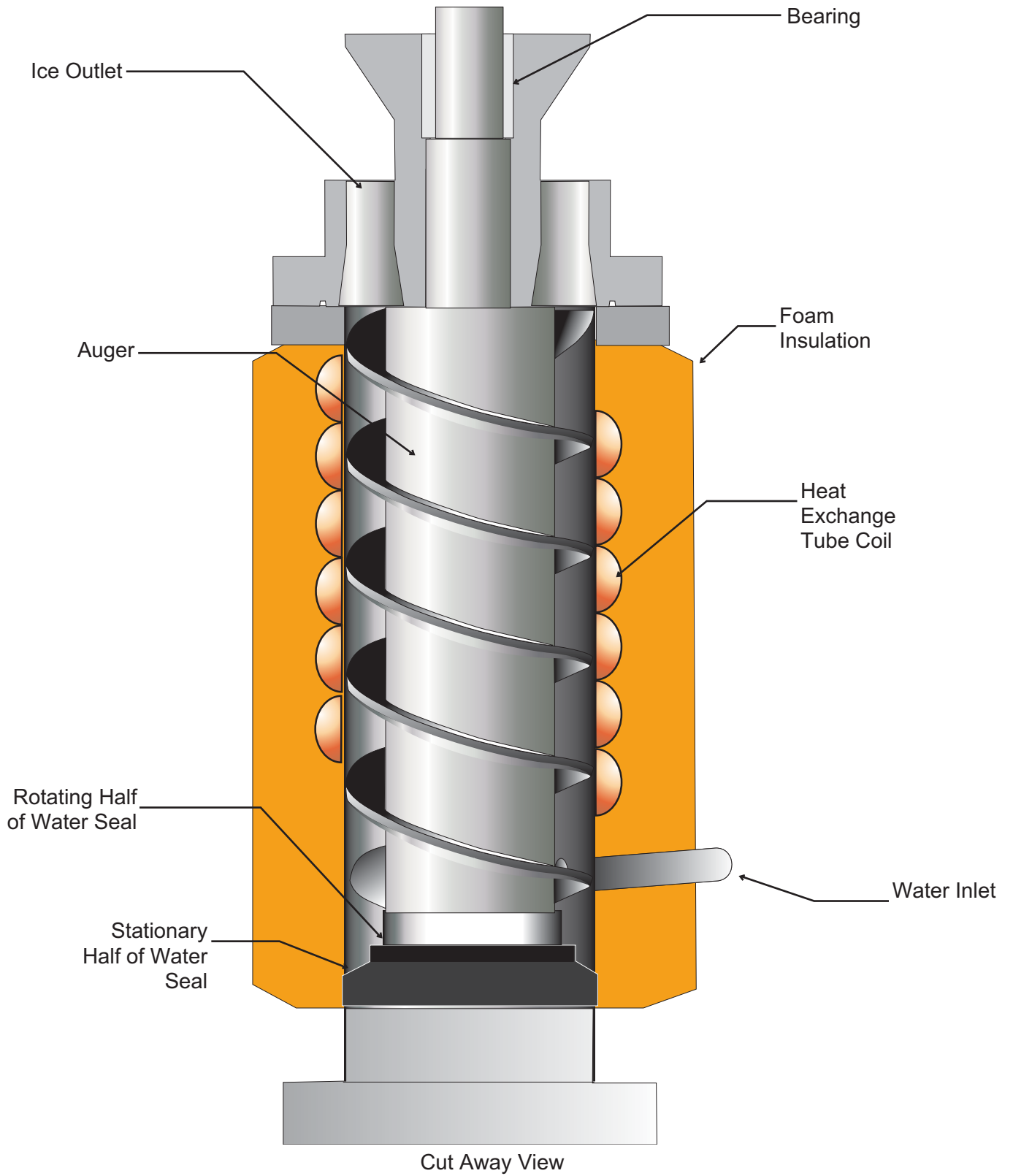

# GEMU090

## Service

### Control System

The control system operates the machine. The controller operates on 12 volts AC, supplied by the transformer. It uses an ultrasonic ice sensor to measure ice level. The ultrasonic system transmits sound waves into the ice storage bin and measures the return time, when the return time is longer than the preset time for bin full, the controller switches the ice machine to an ice making mode. During ice making the compressor, fan motor and auger motor are operating.

The control system has two safeties: It will not operate the machine without water and it will not operate the machine if the auger motor is drawing too much current or if it isn't drawing any current. The water sensor is checking the conductivity of the water in the water reservoir. If there is no water in the reservoir the conductivity will be zero and the controller will either not start ice making or will stop making ice.

The current or amps of the auger motor are continually monitored by the controller during ice making. If the current is too high, indicating an overload, the controller will stop ice making. If the current is zero, indicating an auger motor failure, the controller will also stop ice making.

The control pad has two switches and three lights. The left switch button is On/Off. The right switch button is Clean/Reset. The left Ice Making light is a status light, it is ON when the machine has been switched to an ice making mode. The center light is a Water light, it will be ON when the controller has sensed that there is no water available. It will go out when the water supply has been restored. The right light is a Time to Clean indicator light. It is switched ON by the controller after six months of power connect time. It will go out after the machine has been cleaned following the process in the Maintenance section.

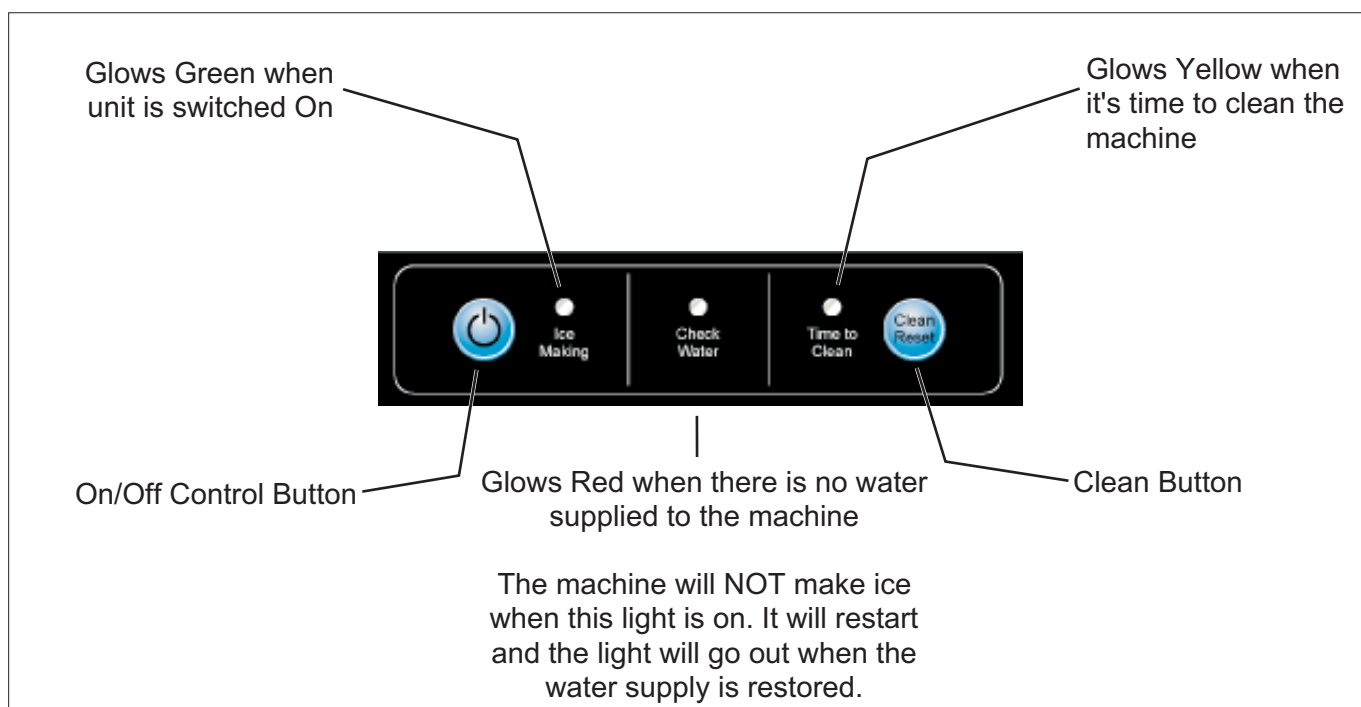

**Control Panel**

# GEMU090

## Service

### Water System

The auger is driven at about 11 RPM by the gear reducer. The gear reducer is a sealed component and does not require lubrication, as it contains a charge of grease. The auger motor drives a set of gears that all together reduce the motor speed to the 11 RPM output speed and correspondingly increasing the torque. The output shaft of the gear reducer is hollow to accept the square end of the auger.

The auger is one of the key components in this product. It is a precision machined part cut from solid stainless steel bar stock. It fits the inside of the evaporator tube very closely and is aligned by the gear reducer at the bottom and a self lubricating bearing at the top.

As ice is made and forced up the evaporator, the auger is being pushed down. That thrust is supported by the bearings in the gear reducer. Those bearings also provide alignment for the bottom of the auger, keeping it centered in the evaporator tube. The top bearing provides auger alignment at the top.

Water is kept from leaking out the bottom of the evaporator by the water seal. The water seal is the type of seal called a face seal, with the outside diameter of a stationary half pressed against the inside of the evaporator tube and a rotating half attached to the bottom of the auger. The sealing action takes place where the faces of the two halves rub together.

Water is the raw ingredient of ice and it enters this machine through the compression fitting in the back. That leads to the float valve and reservoir. When the float is not supported by water, the float arm is down and the attached float valve is open. As water enters the reservoir, it also flows into the reservoir's outlet tubing which leads to the evaporator water inlet, filling the evaporator. The float rises as the water level is increased until it has lifted high enough to force the water valve to close, stopping the flow of water. When the machine is making ice, the water level will drop

slightly and water will flow into the reservoir through the partially open float valve. It will flow in continually as ice is made.

**Water quality.** Nearly all water supplies contain some impurities or minerals. When ice is made those minerals can remain behind in the ice machine and coat its surfaces with a hard, stone like substance known as scale. This scale must occasionally be removed by scale remover. Scale remover is a food grade acid that will dissolve the scale so it can be washed away. Note: it is important to ALWAYS dilute the scale remover when using it on this machine. Never use undiluted scale remover.

Some water treatment devices make very clean water, Reverse Osmosis is one of those and this machine may be used with RO water as long as the conductivity is greater than 10 microsiemens/cm. Use of de-ionized water is not recommended and will void the warranty.

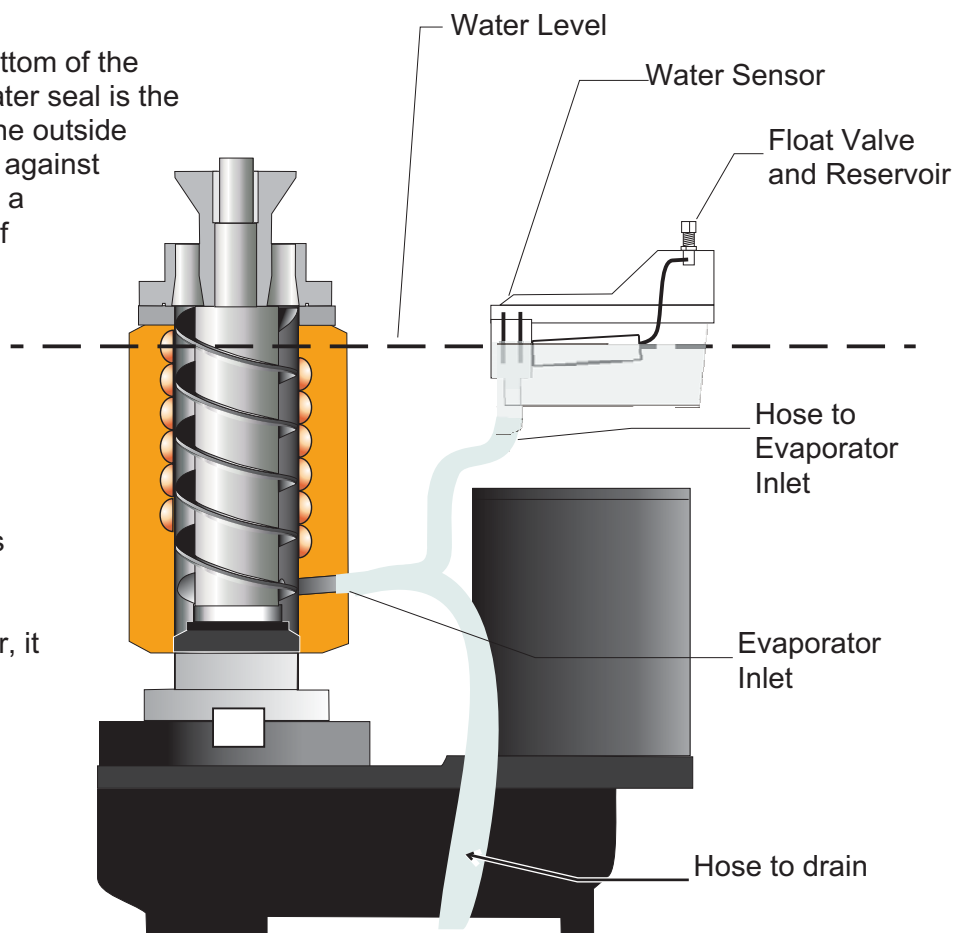

# GEMU090

## Service

### Storage

---

The ice storage system is made up of a plastic lined ice storage bin, covered by an insulated top panel and an insulated swing open door with gasket. The ice storage bin is foamed in place, so the side panels are not removable.

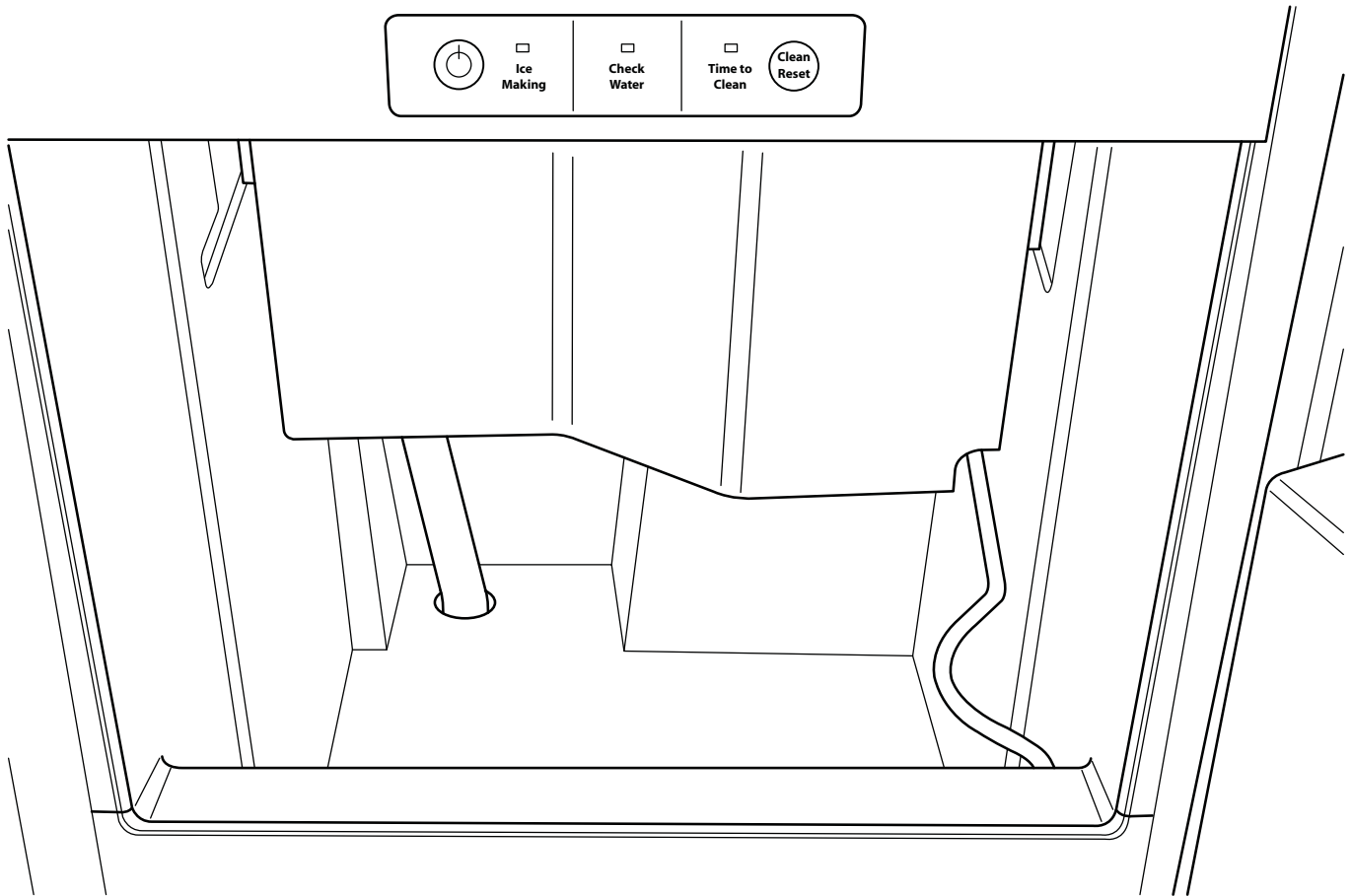

# GEMU090

## Service

### Performance and Technical Specs

---

#### Overall:

- Refrigerant: 4.5 oz R-134a
- Compressor: Hermetic, 1390 BTUH
- Condenser: Forced draft
- Fan blade: 3 blade, 6 inch
- Evaporator: Stainless steel tube, copper coil jacketed
- Metering device: Cap tube
- Auger drive: output speed 11 RPM
- Water valve: Float in reservoir
- Drain pump: Magnetic drive, controlled by pressure switch
- Bin control: Ultrasonic

#### Electrical Components:

- Compressor - 2.8 - 3.1 amps
- Fan motor
- Auger motor, amp draw .4 - .5 amp
- Drain pump motor
- Drain pump switch
- Controller
- Transformer
- Water sensor
- Ice level sensor
- Membrane switch assembly

#### Control Timers

- Power interruption, time to restart after power restored: 2 minutes
- Auger motor overload, time to restart: 4 minutes
- Auger motor overload, restart window: 60 seconds
- Auger motor low current, time to restart: 20 minutes
- Auger motor low current, restart window: 60 seconds
- Clean cycle time: 40 minutes total.

---

Note: During the auger motor restart window times, there is no visible indication that the unit is in a restart mode.

---

#### Light Blink Information

- All blink once and repeat every 2 seconds: Auger motor overload
- All blink twice and repeat every 2 seconds: Auger motor low current
- All blink once and repeat every 10 seconds, controller failure.
- Water light blinks red: water supply failure

#### Controller Reset:

- Cycle power off and on

**Diagnostic Codes:** No diagnostic codes are kept

**Time to Clean indicator light** standard interval to switch light on is 6 months, it can be changed to once per year or disabled.

To Adjust:

1. From Off, press and hold the On/Off and Clean Reset Buttons for 5 seconds.
2. Press and Hold the Clean Reset Button for 5 seconds, then press On/Off. Then press On/off again to cycle thru the settings:

	Ice Making	Water	Time to Clean
6 months	On	Off	Off
1 year	Off	On	Off
Disabled	Off	Off	On

Light will automatically go out after a few seconds of inactivity. Press Time To Clean to lock in the new setting.

Quick reset of time to clean light: Press and hold the Clean Reset button for 3 seconds.

# GEMU090

## Service

### Electrical Sequence

---

Upon power being supplied, all the lights will blink once and the control system will immediately check for water in the reservoir. If there is water no further action will occur until the On/Off button is pushed.

Pushing the On/Off button starts the machine. The Ice Making light will switch on. The auger motor, compressor and fan will begin to operate. Those three components will continue to operate until the Ice Level Control detects that ice has built up to the pre-set level. At that point the control system will begin a shut down process by shutting off the compressor and fan motor.

After sixty seconds the auger motor will shut off. The purpose of this is to remove any ice from the evaporator so the auger motor can restart with minimal load.

The machine will restart after the ice level has fallen one inch or more.

#### Other Control Functions:

To Shut Off: Push and release the On/Off button. If the machine was off because the bin was full, the unit will be switched to Off immediately. If the unit was making ice, the compressor and fan motor will shut off immediately, and the auger motor shut off in sixty seconds. To shut the unit off immediately while making ice, push and HOLD the On/Off button until it shuts off.

To Clean: See Maintenance section for step by step process. Pushing the Clean button while the Ice Making light is On does not start the clean cycle, it is only active from Off. Pushing the Clean button from Unit Off starts the clean cycle:

- Time to Clean light flashes
- Auger motor operates for twenty minutes
- Auger motor and compressor operate for twenty additional minutes
- Unit shuts off, Time to Clean reminder light switches Off.

#### Safety Shut Downs:

Lack of water. It is critical that the unit not operate without a full charge of water. The water sensor in the reservoir is used to check continuity through

the water it is in contact with. If there is no water present, there will be no electrical continuity and the control system will stop the machine and cause the Check Water light to blink Red, alerting the user of a lack of water. When water has returned to the reservoir, the unit will automatically restart.

Power interruptions: If the power to the machine failed during normal operation, the machine will automatically restart after a two minute delay. If the unit had shut down because of a safety, then the unit remains in the shut down state.

Auger motor overload: If the auger motor current exceeds the preset limit for a certain time, the controller will shut the compressor and auger motor off. The controller will keep the compressor and auger motor off for four minutes, then restart them. The controller records each overload as a strike. It will erase the strike(s) if the current draw in the sixty seconds following the restart is below the preset limit. If within the sixty seconds after the restart the current again exceeds the limit, the controller again shuts the machine down and a second strike is recorded and four minutes later a second restart occurs. If the current is again excessive the third time, the unit will stop restarting and the lights will flash on and off every two seconds.

Auger motor low current: If the controller senses the auger motor is not drawing any or minimal current, it will shut the compressor and auger motor down for twenty minutes before attempting a restart. The twenty minutes are intended as time for the auger motor to cool off if it has shut down on its internal overload. The controller records that as a strike. If in the next sixty seconds the auger motor begins to draw current the strike is erased and normal operation resumes. If the current is still low, a second strike is recorded and the unit will wait another twenty minutes before attempting a third restart. If the third restart is normal, the strikes are erased and normal operation is continued. If the unit fails again, the unit will stop restarting and the lights will flash twice on and off every two seconds.

Controller Failure: If all lights are flashing once every 10 seconds the controller has identified an internal failure and must be replaced.

**GEMU090**  
**Service**  
**Service Diagnosis**

<b>Problem</b>	<b>Likely Cause</b>	<b>Probable Solution</b>	
No ice	No power	Plug unit into power supply	
	Unit switched off	Push and release on/off button	
	No water, water diagnostic light is on		Restore water supply, check sensor. If RO water is too pure, unit cannot operate.
			Check float valve for restriction
			Check float valve shut off lever position
	Compressor on, fan on, auger motor not operating		Check auger motor for voltage, if none, replace controller. If there is voltage, check auger motor windings, if open, replace auger motor.
	Compressor on, fan on, auger motor cutting off on over amp safety		Check evaporator for ice. Thaw out and retry. Check top bearing and condition of auger. Replace if worn. Operate unit for a short time with auger out of machine, water shut off and water sensor bypassed. If auger motor still overloads, replace gear reducer.
	Compressor on, auger on, fan blade not turning		Check fan blade for ease of rotation, remove any blockage and retry. Check fan motor, replace if not turning freely or motor windings open.
	Auger motor on, fan on, compressor not drawing power		Check compressor start relay, check compressor windings.
	Auger motor on, fan on, compressor cutting off on overload		Check compressor. See component diagnostics.
	Compressor on, fan on, auger motor on, ice sweep not turning		Check ice sweep. If tight to auger, auger is not turning. Gears stripped, replace gear reducer.
	Unit off on auger motor open safety		Check connections to auger motor, if voltage to motor and it does not operate, replace motor.
	Unit plugged in but no power		If pump model check for water back up or open safety switch.
			Check transformer, replace if not supplying 12 volts AC to controller.
Check switch membrane. See component diagnostics.			
If transformer and membrane are good, replace controller.			



**GEMU090**  
**Service**  
**Service Diagnosis**

<b>Problem</b>	<b>Likely Cause</b>	<b>Probable Solution</b>
No ice, continued	Ice level sensor failure	With power on and Ice Making light on, check connector, if secure jump the two middle pins at J2 (bin stat) on the controller together. Unit should start. If it does, replace the sensor, if not, replace the controller.
	Auger motor on but compressor and fan motor are off.	Restart unit. Check for power to compressor and/or fan motor. If none, replace controller. Ice Making light blinking. Condition is temporary, unit has been switched off.
	Ice making light on, nothing operating.	May be in a restart window. See page 7.
Not keeping up, makes ice but less than normal	Dirty condenser	Vacuum condenser fins
	Air flow blocked	Check for vent blockage
	Gravity drain restricted	Check drain, clear of restriction. Ensure it has a proper air vent.
	Pump drain slow	Check for proper pump switch operation and drainage
	Scale on evaporator and auger	Clean with scale remover. See Maintenance section.
	Torn door gasket, door does not close tightly	Check gasket and door fit.
Makes ice but also an unusual noise	Panels vibrating	Check panels, adjust fit, tighten screws
	Fan blade rubbing	Check fan blade for foreign object. Remove same. Check alignment.
	Scale on evaporator and auger	Clean with scale remover. See Maintenance section.
	Drain pump cuts in and out.	Check valve failure, replace.
	Tubes rubbing	Check for tube contact to panel or another tube.
	Unit in very cold conditions	Do not operate unit below limits
Water Leak	Drain tube off or cracked	Check/repair drain tube
	Water inlet connection loose	Check/tighten connection
Water flows continuously	Float valve not shutting off	Check float, if stuck free it. If leaking by when full, replace the valve.

# GEMU090

## Service

### Component Diagnostics

#### Membrane Switch

Unplug and check connector pins (left side is pin 1), read about 10 ohms when activating the button, and OL when not pressing the button: Pin 2-3 On/Off Switch; 4-3 Clean Reset Switch



#### Compressor

Check temperature of compressor, if very hot, add access valves to refrigeration system and check system pressures. If very low, add very small amount of R-134a. If pressure does not improve, capillary tube may be restricted. If pressures improve find and correct refrigerant leak.

If compressor temperature is normal and compressor is drawing high amps, check start relay.

If relay is good and compressor is not overheating but drawing high amps, replace compressor.

#### Pump Switch - Pump model only

The pump switch activates the pump based on pressure to it from water inside the drain hose to the pump inlet. It is normally open. When pressure increases the switch closes, turning on the pump motor until the pressure falls.

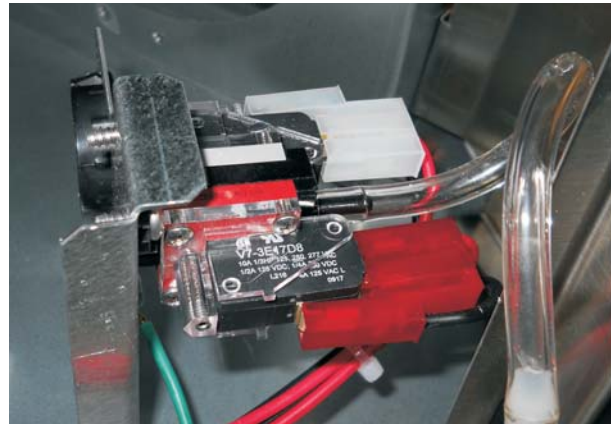

The safety switch (the red one) is normally closed and operates at a higher activation pressure than the pump switch. It stops operation of the machine if it opens.

#### Ice Level Sensor

To operate, the unit must have:

- Power to the controller
- Water sensed
- Call for ice

With power on and Ice Making light on, check sensor connector, if secure and the unit not operating, remove connector and jump the two middle pins at J9 on the controller together. Unit should start. If it does, replace the sensor, if not, replace the controller.

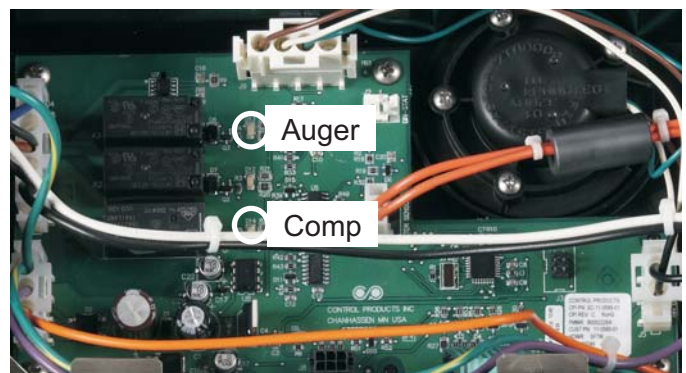

# GEMU090

## Service

### Ice Capacity

---

The rate of ice making is relatively fixed, it depends upon the heat load and the ambient temperature the machine is operating in. As either increase the amount of ice made will decrease.

The machine will work to keep the ice bin full. A full bin of ice is when the ice level is even with the top of the front of the bin. When the ice level drops an inch or more the machine will restart.

A capacity check will provide some idea of how much ice is being made.

1. Operate the machine for 10 minutes until it is stabilized.
2. Catch the ice as it is made for 15 minutes.
3. Weigh the ice and any melted water.
4. Multiply the weight from step 3 by 96 to get 24 hour capacity.
5. Compare to the chart below:

90°F. Air, 70°F water	59 lb / 24 hours
70°F. Air, 50°F. water	87 lb /24 hours

---

Note: Mineral scale build up inside the evaporator will reduce the ice making rate, as will any lint or dirt on the air cooled condenser or fan blade. All ice making capacities listed by Ice-O-Matic are for clean, new machines.

---

The ice storage bin is not refrigerated; it is an insulated ice chest, so there is meltage. A restricted drain or poorly operating drain pump will allow water to puddle in the bin, increasing the ice melt rate. A stopped up drain will cause the bin to fill with water.

### Refrigerant charge.

The charge is very small. Any leak will immediately result in a loss of ice making capacity and continued leaking will result in no ice being made. The system is sealed, access must be by clamp on valves, which must be removed after the repair is completed.

### Noise

Normal ice making produces very little noise; there will be sound from the compressor, fan and auger drive motor. If there is a drain pump it will cycle occasionally too. If the machine is making an unusual noise that might be a sign that it needs to be cleaned of mineral build up.

# GEMU090

## Service

### Removal and Replacement

---

#### Component Access

The machine is designed to be cleaned while built in. See the Maintenance section for more information.

Most components require the machine to be removed from a built-in situation:

- Fan motor – side service panel
- Controller – top panel
- Auger motor – top panel, back panel
- Ice sensor – top panel
- Drain pump – side service panel
- Top bearing – top panel
- Gear reducer – top panel, back panel
- Ice sweep – top panel
- Water seal – top panel, back panel, bin back panel
- Water reservoir or float - top panel

#### Evaporator / Auger / Water Seal / Gear Reducer Service

The auger, top bearing, water seal and gear reducer can be replaced without disturbing the refrigeration charge. If the evaporator must be replaced, then the refrigeration system must be accessed so the charge can be recovered.

#### Evaporator construction

The evaporator is made up of a stainless steel tube, wrapped with a coil of copper and then heavily insulated. There is no refrigerant path to the water inside of the evaporator. The inside of the tube is polished and rifled with 12 vertical grooves that help guide the ice straight up the tube.

It is normal for mineral scale from the water to form on the inside of the evaporator tube. That scale must be removed by use of ice machine scale remover using the process described in Maintenance. Heavy scale build up will require the process to be repeated. The inside of the evaporator tube may be sanded vertically to remove tough build up. Do NOT hone or clean with a wire brush on a drill, as horizontal marks on the inside of the evaporator will restrict the flow of ice.

A damaged evaporator must be replaced.

The auger can also have scale build up which must be removed. It works best when it is clean and shiny. Note that a wet auger will appear clean but when dry the scale will be visible. Dry off the auger (use your heat gun) to determine if it's clean. If the machine has been operated with worn bearings, the auger may have rubbed the evaporator wall. If the spiral edges or flights of the auger are damaged, the auger must be replaced.

The ice breaker at the top of the evaporator contains the pressed-in bearing. This bearing must not be greased. If worn, the breaker with bearing can be replaced.

The gear reducer is a sealed unit. The only service part available for it is the drive motor and drive motor capacitor.

#### Lubricants and Sealants

Food grade lubricant is useful in repair of this model. Ice-O-Matic part number 6051036-01.

Food grade sealant is needed in repair of this model. Ice-O-Matic part number 6051011-01.

# GEMU090

## Service

### GEM090 Gearbox Access & Removal

1. Shut off water supply
2. Remove drain plug inside bin compartment
3. Disconnect power supply or unplug unit

	<p><b>⚠ WARNING</b></p> <p><b>Hazard of Electrical Shock.</b></p> <p>Disconnect Electrical Power Before Servicing.</p>
---	--

4. Uninstall unit and pull out as needed for top and back access.
5. Remove top panel
6. Remove back panel
7. Remove ice chute/bin wall by unscrewing 2 thumb screws and lifting it out

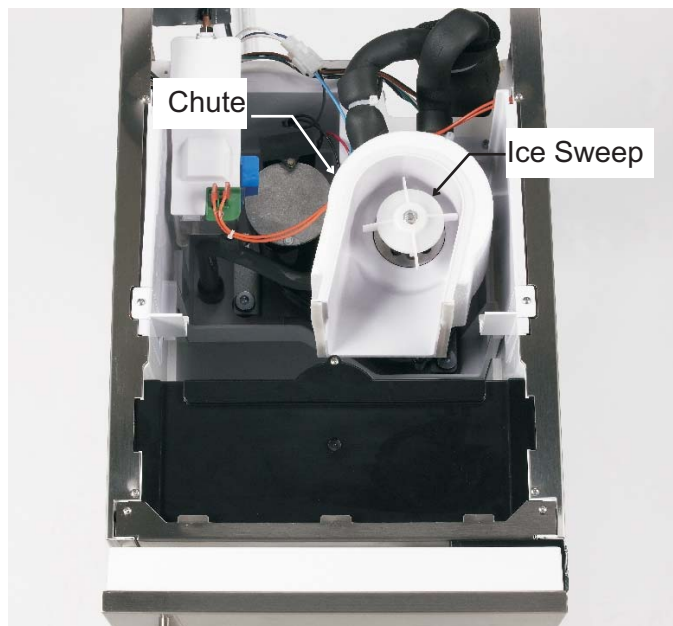

8. Remove 2 orange wires from water level sensor (on top of float tank)
9. Rotate ice sweep counter-clockwise and remove ice sweep

10. Lift and remove ice chute

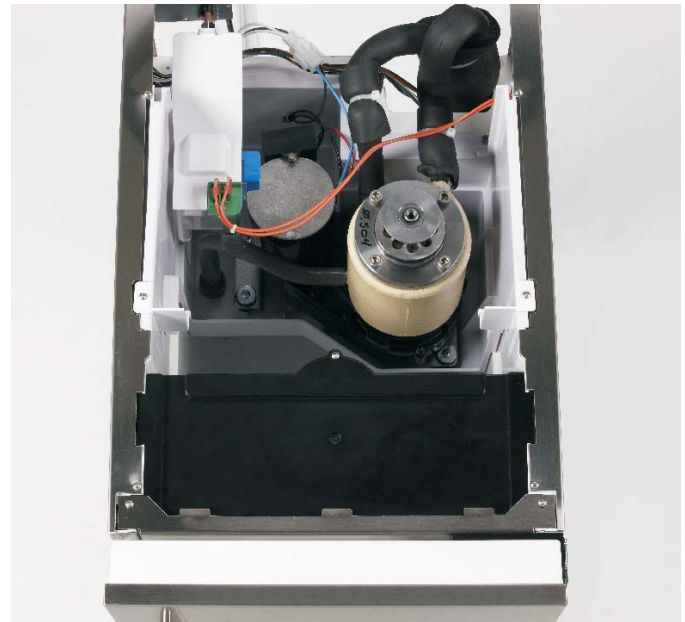

11. Remove 4 screws securing float reservoir & set aside
12. Remove gray water tube from evaporator inlet
13. Disconnect power connection to auger motor
14. Remove 4 bolts securing breaker head to freezer by using 1/4" allen wrench (socket type - best method)

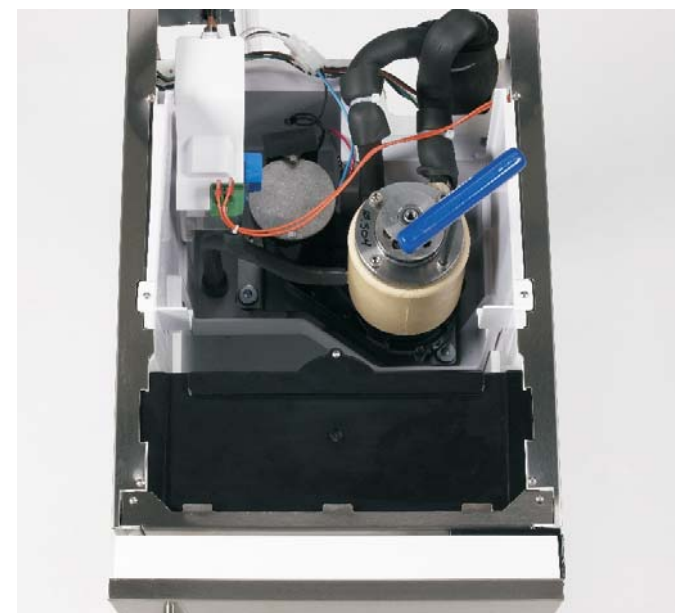

# GEMU090

## Service

15. Remove breaker & set aside
16. Pull auger from freezer by lifting straight up (be careful as auger has sharp edges!)

---

Note: If auger does not lift freely, see Auger Removal Procedure.

---

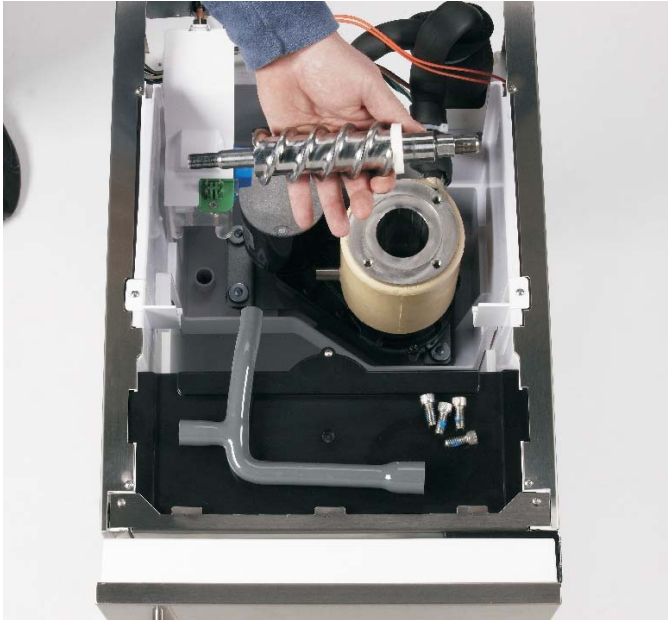

17. Inspect auger flights for signs of wear
18. Inspect evaporator barrel for signs of radial scoring
19. Remove 4 screws securing gearbox bracket to compartment base

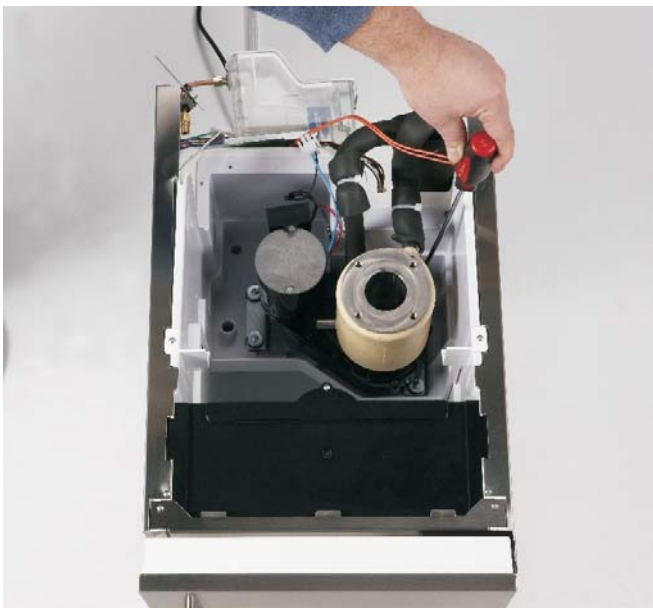

20. Carefully lift and rest gearbox & bracket against back of compartment lip

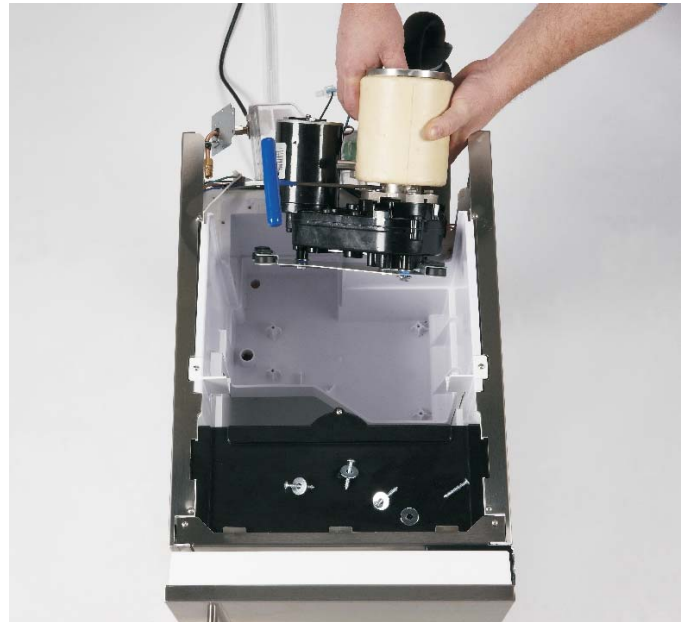

21. Remove four 5/32" allen head screws holding adapter to evaporator



22. Remove evaporator from gearbox

\*\* tools needed-1/4" & 5/32" allen wrench (T handle or socket type suggested), Phillips screwdriver - 12 inch or longer recommended.

Replace gear reducer and install a new water seal.

# GEMU090

## Service

### Water Seal Replacement

- 1 Go through the prior steps to remove the gear reducer.
- 2 Remove rotating half of water seal from bottom of auger.

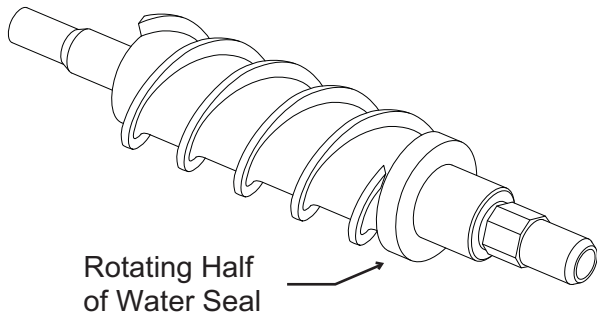

- 3 Clean auger of any sealant at water seal mounting position.

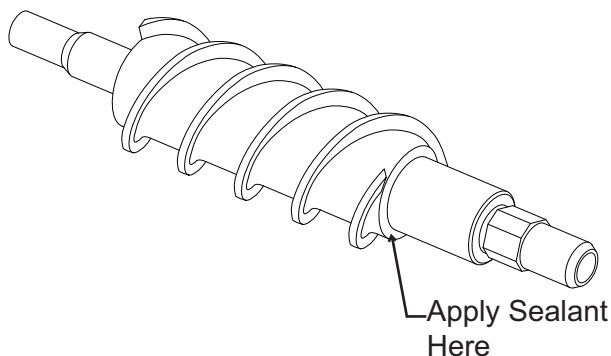

- 4 Add a small bead of food grade silicone sealant to the shoulder of the auger where the water seal will go.

---

Note: Do NOT touch the mating surfaces of the water seal with fingers or sealant.

---

- 5 Lubricate / moisten (lightly - use food grade lube) only the rubber part of the new water seal and slide it onto the auger, rubber side against the auger shoulder. Force it onto the sealant as far as it will go.
- 6 Remove the stationary half of the old water seal from the bottom of the evaporator.

- 7 Lubricate or moisten the outer edge of the new seal and push it into the bottom of the evaporator tube until **flush with the bottom of the tube**. Be sure it is in as straight as possible.

---

Note: Do NOT touch the inner ring of the water seal with fingers or sealant. Wipe off with rubbing alcohol if they were touched.

---

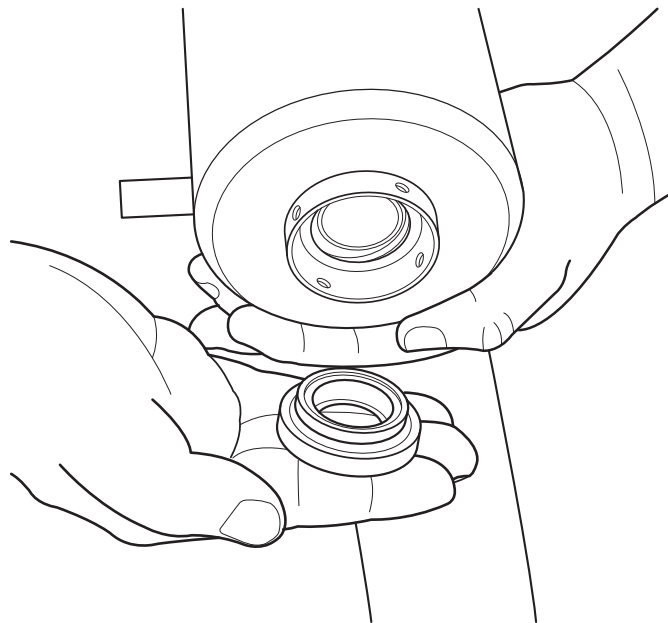

- 8 Position the gear reducer under the evaporator.
- 9 Push the gear reducer and adapter flange up into the bottom of the evaporator until the mounting holes line up. This forces the stationary half of the water seal to the correct location.
- 10 Screw in the four allen head screws into the side of the bottom of evaporator tube.
- 11 Remount the gear reducer and evaporator assembly into the ice machine. Secure the mounting pan with the original screws.
- 12 Carefully lower the auger with the other half of the water seal attached into the evaporator tube. Rotate auger until it slips into place.

# GEMU090

## Service

- Slide breaker onto auger shaft. Secure with the original four allen head bolts.
- Reverse the balance of the steps to complete putting the machine back together.

### Gear Reducer Replacement

- The gear reducer contains no internal serviceable parts. Replace as a unit.
- Follow all steps to remove gear reducer from evaporator.
- Remove bolts holding gear reducer to mounting plate.
- Separate gear reducer from mounting plate and attach a new gear reducer.

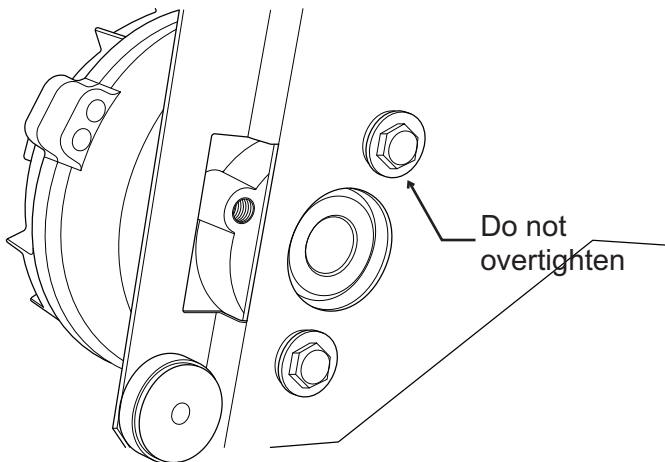

Note: Do NOT overtighten bolts securing gear reducer to mounting plate. Tighten only until the washer contacts the blue grommet.

### Ice Breaker Replacement

- Disconnect power supply or unplug unit
- Uninstall unit and pull out as needed for top access.
- Remove top panel
- Rotate ice sweep counter-clockwise and remove ice sweep
- Remove ice chute
- 

Remove 4 allen head screws holding breaker to evaporator.

- Lift breaker off and replace with a new part.

Note: Be sure auger shaft is smooth and undamaged. A dark finish at the bearing area is normal. Replace auger if damaged.

### Auger Replacement

Auger replacement requires a new water seal. Follow all steps to replace the water seal except substitute a new auger.

### Auger Removal Procedure

If the auger does not lift freely, it may be stuck in the gear reducer. To release it:

- Remove ice sweep.
- Remove 4 allen head bolts holding breaker to evaporator.
- Place 4 hex nuts (5/8 size) as spacers between the breaker and the top of the evaporator.

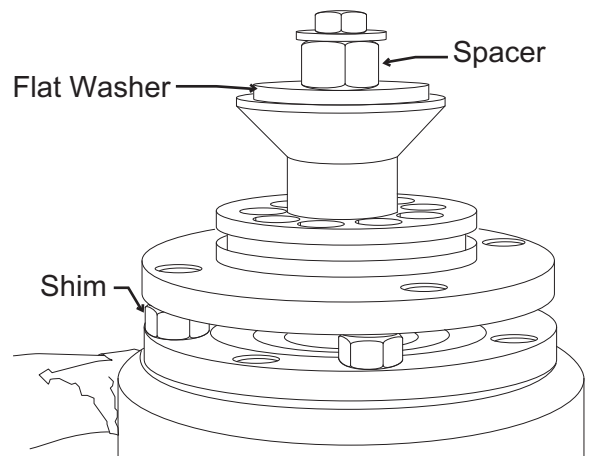

- Place a large flat washer or suitable hex nut (as a spacer) over the top of the breaker.
- Thread a 5/16 - 18 x 1 inch bolt into the top of the auger thru the washer and/or hex nut and screw the bolt into the auger. As it tightens against the nut it should lift and loosen the auger. Once the auger has moved it should lift out easily.



# GEMU090

## Service

### Evaporator Replacement

---

- 1 Go through all steps to remove the gear reducer.
- 2 Add temporary refrigeration system access valves to the discharge and suction sides of the refrigeration system .
- 3 Recover the refrigerant.
- 4 Un-sweat the suction line and cap tube connections from the evaporator.
- 5 Remove original dryer.
- 6 Attach permanent access valves to system.
- 7 Attach dry nitrogen to system and purge at about 1 lb pressure while brazing all connections, including access valves, dryer and evaporator.
- 8 Remove nitrogen source, evacuate system to 300 microns or less.
- 9 Weigh in the nameplate charge.
- 3 Disconnect electrical power.
- 4 Remove control box cover
- 5 Unplug all wires.
- 6 Remove screws holding controller to box.
- 7 Remove controller.
- 8 Before touching replacement controller, touch a metal surface of the cabinet to discharge any static electricity.
- 9 Place new controller in control box, connect all wires previously removed.
- 10 Reverse remaining steps to reassemble.

### Water Reservoir

- 1 Pull unit out to get access to top and back panel.
- 2 Shut water supply off.
- 3 Pull drain plug and drain all water. Return plug to its original position.
- 4 Loosen nut at water valve inlet and separate inlet tube from reservoir valve.
- 5 Pull outlet hose off reservoir tank.
- 6 Remove screws holding reservoir to unit and lift off.
- 7 Reverse steps to reassemble.

### Controller

- 1 Pull out to get access to top panel.
- 2 Remove top panel.

### Ice level sensor

- 1 Pull out to get access to top panel.
- 2 Remove top panel.
- 3 Disconnect electrical power.
- 4 Remove control box cover
- 5 Unplug wire at J9.
- 6 Remove 5 screws and lift sensor from control box.
- 7 Replace with new part.
- 8 Reverse remaining steps to reassemble.

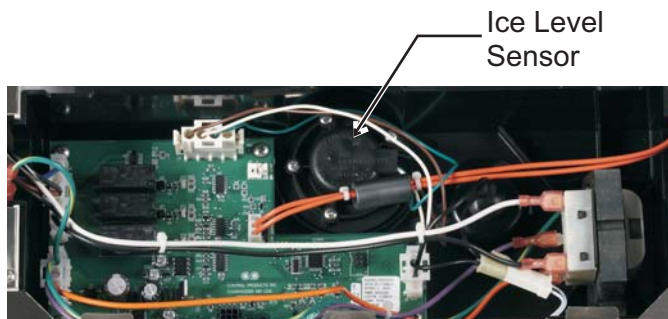

# GEMU090

## Service

### Drain Pump (if equipped)

---

- 1 Shut off water supply
- 2 Remove all ice and/or any standing water.
- 3 Disconnect power or unplug unit
- 4 Uninstall and pull unit out to get access to left side service panel.



- 5 Remove five screws and the service panel.
- 6 Disconnect electrical plug to pump motor
- 7 Disconnect drain hose from pump inlet
- 8 Disconnect discharge hose from pump
- 9 Remove two 3/8 inch nuts holding pump to base, lift pump up and out.
- 10 Reverse steps to reassemble.

### Fan Blade or Motor

- 1 If equipped with drain pump follow all steps to remove pump.
- 2 Unplug fan motor connection.
- 3 Remove four screws holding fan motor brackets to shroud.
- 4 Pull fan blade and motor from unit.

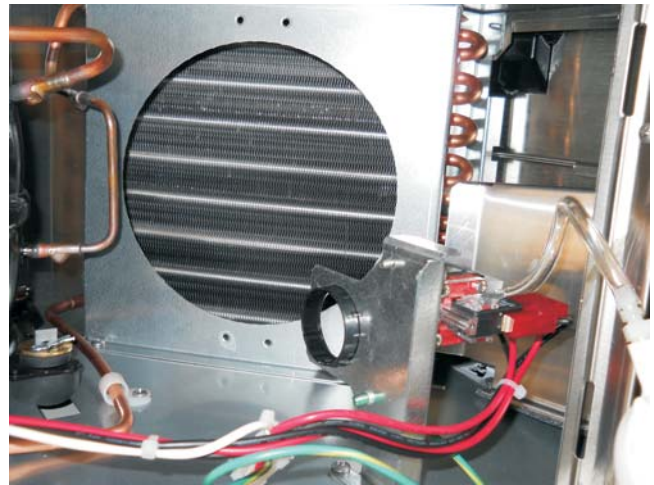

- 5 If not equipped with a drain pump:
- 6 Shut off water supply
- 7 Remove all ice and/or any standing water.
- 8 Disconnect power or unplug unit
- 9 Uninstall and pull unit out to get access to left side service panel.
- 10 Remove five screws and the service panel.
- 11 Unplug fan motor connection.
- 12 Remove four screws holding fan motor brackets to shroud.
- 13 Pull fan blade and motor from unit.
- 11 Service blade or motor and reverse to reassemble.

# GEMU090

## Service

### Compressor replacement.

Note: If built in the unit will need to be pulled out.

Note: Placing it over the leg leveler and next to the strut works the best.

- 1 Shut off water supply
- 2 Disconnect power supply or unplug unit
- 3 Uninstall unit and pull out as needed for side and back access.
- 4 Remove all panels and door:
  - Back panel including drain and power supply panels.
  - Side service panel
  - Kickplate
  - Top panel
- 5 Go through all steps to remove drain pump and/or fan motor.
- 6 Remove drain hose from unit.
- 7 Obtain or make an 11" prop from 3/4" PVC or similar.
- 8 Remove 2 screws (at back) holding base to side panels
- 9 Remove screws holding strut to base
- 10 Remove screw holding left side panel to base
- 11 Loosen BUT DO NOT REMOVE two screws at front holding side panels to base
- 12 Lift back of unit up and support with the 11" prop.
- 13 Add temporary refrigeration system access valves to the discharge and suction sides of the refrigeration system.
- 14 Recover the refrigerant.
- 15 Remove the four hair pins securing compressor to chassis.
- 16 Disconnect wires, overload and relay from compressor.
- 17 Push back suction line insulation.
- 18 Unsweat the discharge and suction connections at the compressor.
- 19 Remove the compressor from the unit.
- 20 Remove dryer from unit.
- 21 Attach permanent schrader access valves to unit.
- 22 Attach dry nitrogen supply to access valves, purge at about 1 lb pressure during brazing.
- 23 Install new dryer.
- 24 Install new compressor. Install at least 3 of the hair pins to secure the compressor. The fourth is optional.
- 25 Make all braze connections needed to seal system.
- 26 Remove nitrogen supply. Evacuate system to at least 300 microns.
- 27 Weigh in nameplate charge.
- 28 Reconnect all wires, components and panels removed to access compressor.
- 29 Reinstall unit. Operate unit and test.

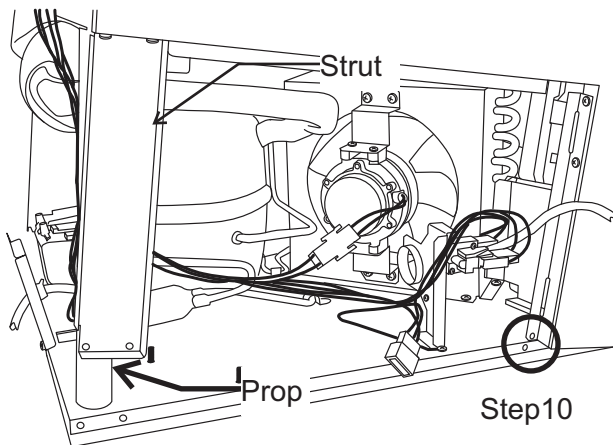
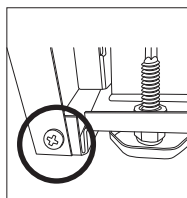

# GEMU090

## Service

### Bin and Cabinet

---

The bin and cabinet can be separated from the base. Either the ice making evaporator system must be lifted out and securely suspended or the refrigeration system opened and the connections to the evaporator unbrazed.

- 1 Remove the unit from its installed position.
- 2 Disconnect water supply.
- 3 Disconnect / unplug unit from power supply.
- 4 Drain evaporator.
- 5 Empty bin of ice and water.
- 6 Disconnect drain hose from bottom of bin.
- 1 Remove top, back and side service panels.
- 7 Remove door.
- 8 Remove kickplate.
- 9 Remove front service panel
- 10 Remove screw holding service panel bracket.
- 11 Remove two screws holding baffle at right side of condenser.
- 12 Unplug wires from compressor and fan motor. Be sure wires from control box to base are free and disconnected.
- 13 Remove four screws holding each corner of the chassis to the base.
- 14 Remove two screws holding left rear strut to base.
- 15 Remove one screw holding left side panel to base.
- 16 Either go thru the process to remove gear reducer and evaporator from unit **or** recover refrigerant and disconnect at evaporator.

---

Note: If leaving evaporator & gear reducer in unit, have a helper support them while the cabinet is removed.

---

- 17 Lift bin and cabinet off chassis.

### Auger Motor or Motor Capacitor

- 1 Remove the unit from its installed position.
- 2 Disconnect water supply.
- 3 Disconnect / unplug unit from power supply.
- 4 Empty bin of ice and water.
- 5 Remove top panel.
- 6 Remove both bolts holding motor to gear reducer.
- 7 Lift motor winding and capacitor up and out of machine.
- 8 Cut wires and separate winding from capacitor. Change either and reconnect motor to capacitor.

---

Note: Be SURE wires are connected per the label on the motor: Black to Black to Capacitor and Red to Capacitor. If connected incorrectly, motor will turn the wrong way. Output shaft or auger MUST turn CCW (counterclockwise) looking from above or the unit will be damaged during ice making.

---

- 9 Pull rotor from gear reducer (if changing motor)
- 10 Insert new rotor (if changing motor).
- 11 Reinstall winding and capacitor assembly. Secure with the original screws.
- 12 Return all panels to their original positions.
- 13 Reconnect water and power.
- 14 Reinstall unit.

# GEMU090

## Service Parts

This is the illustrated parts list for the GEMU090.

### Table of Contents

Door Components . . . . .	Page 2
Cabinet . . . . .	Page 3
Storage Bin and Ice Chute . . . . .	Page 4
Reservoir, Water Sensor and Misc . . . . .	Page 5
Refrigeration . . . . .	Page 6
Under Bin Parts . . . . .	Page 7
Ice Making Section . . . . .	Page 8
Control System . . . . .	Page 9
Wiring Diagram . . . . .	Page 10
Schematic Diagram . . . . .	Page 11

Service Parts

Door Components

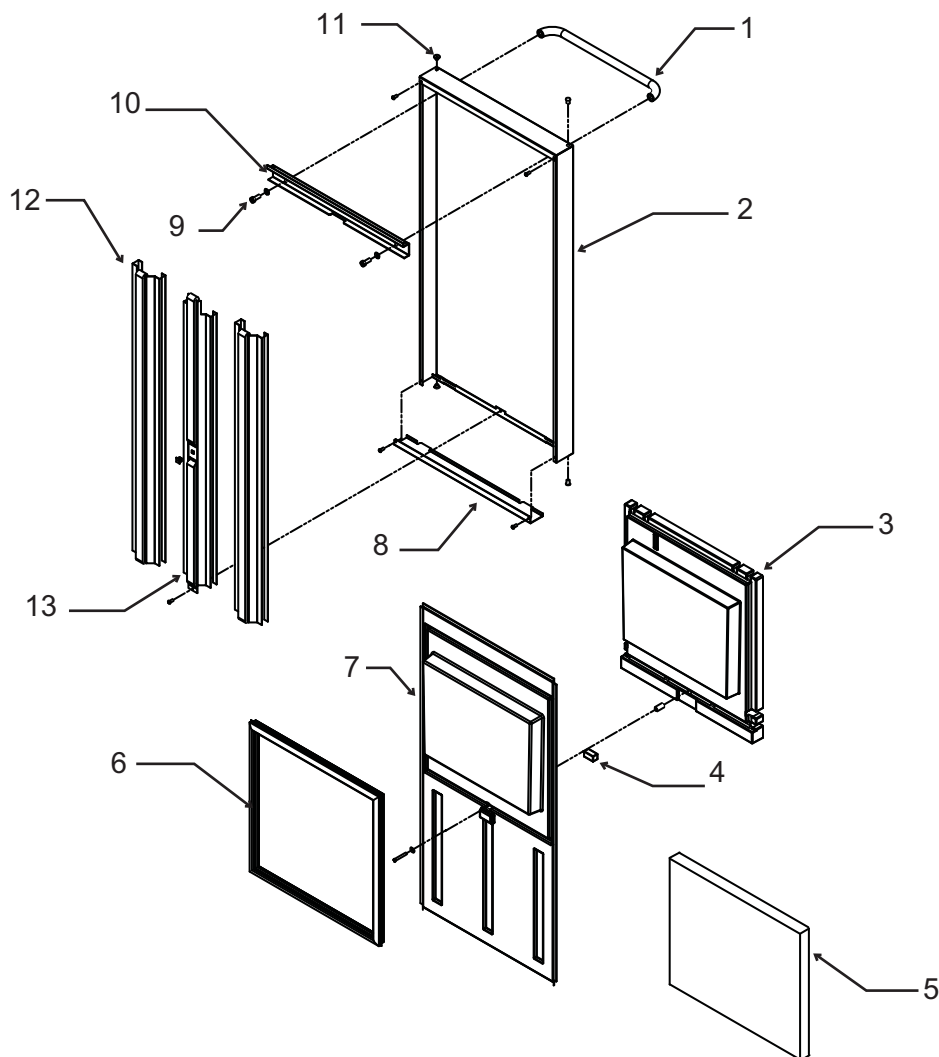

Item Number	Part Number	Description
1	1011448-01	Handle, door
2	1011448-02	Door panel
3	1011448-03	Insulation, upper
4	1011448-04	Magnet, door
5	1011448-05	Insulation, lower
6	1011448-06	Door gasket
7	1011448-07	Liner, door
8	1011448-08	Door bottom
9	1011448-09	Screw, handle
10	1011448-10	Bracket, door handle
11	1011448-11	Bushing, door hinge, same on bottom
12	1011447-12	Door support
13	1011448-13	Door support, center
14	1011448-14	Complete door, assembled. Includes all above parts
	Not Shown, 1011448-117	Hinge Pin, Door to Hinge (Threaded Hinge Pin)
15	1011448-128	Door Cap

Service Parts

Cabinet

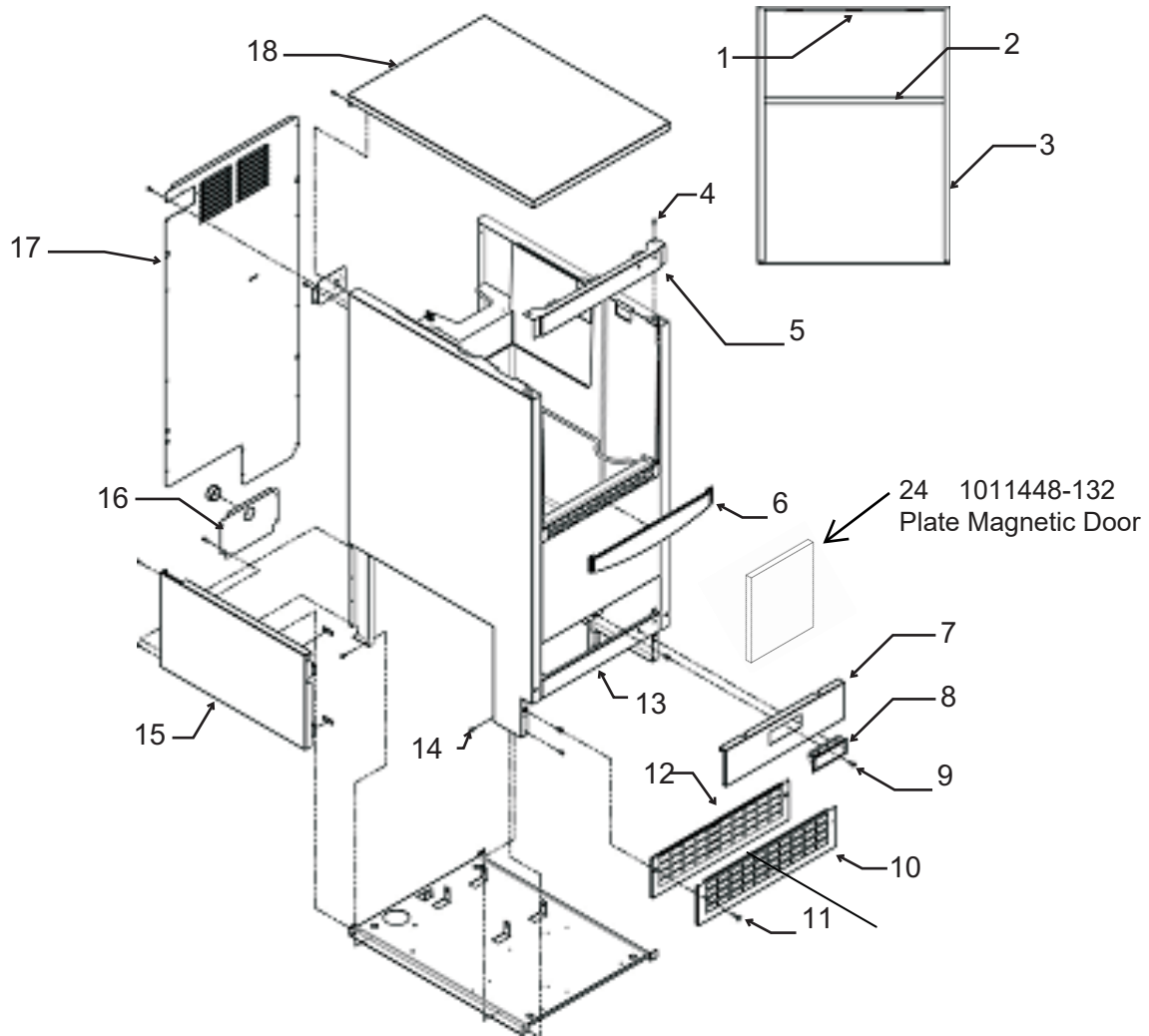

Item Number	Part Number	Description
1	1011448-15	Gasket, top panel
2	1011448-16	Gasket, top panel
3	1011448-17	Gasket, top panel
4	1011448-18	Screw
5	1011448-111	Top hinge bracket
6	1011448-21	Inlay
7	1011448-22	Front service panel
8	1011448-23	Handle
9	1011448-24	Screw
10	1011448-25	Kick plate cover
11	1011448-26	Screw
12	1011448-27	Kick plate
13	1011448-112	Bottom hinge bracket
14	9031046-27	Screw
15	1011448-30	Side service panel
16	1011448-31	Drain panel
17	1011448-32	Back panel
18	1011448-33	Top panel only
18a	1011448-34	Insulation, top panel Not Illustrated
19	1011448-113	Hinge, right top
20	1011448-114	Hinge, right bottom
21	1011351-43	Screw Receptacle Not Shown
		Not Shown, 1011448-117 Hinge Pin, Door to Hinge
22	1011448-121	Scoop Holder
23	9051127-02	Scoop (not shown)
24	1011448-132	Plate Magnetic Door

Service Parts

Storage Bin and Ice Chute

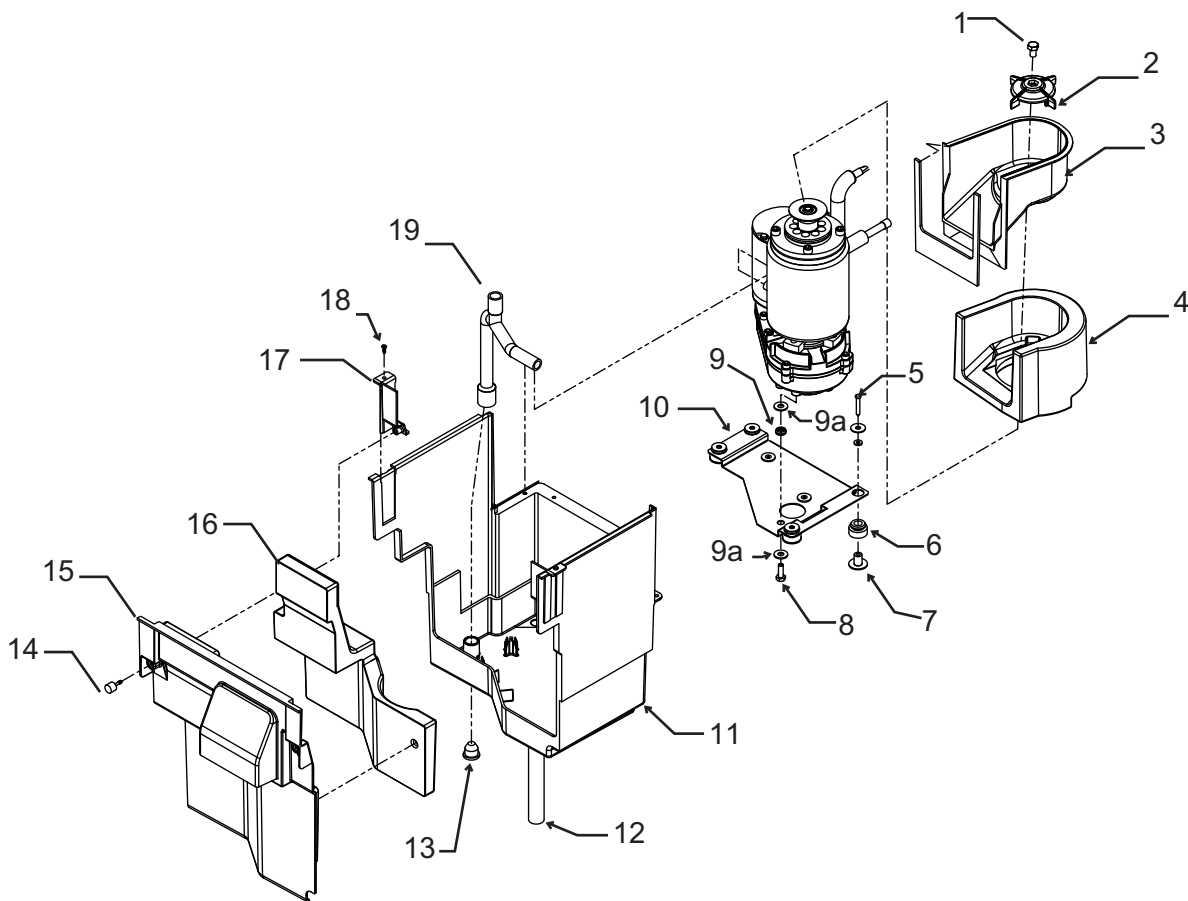

Item Number	Part Number	Description
1	1011448-35	Screw, 5/16-18
2	1011448-36	Ice sweep
3	1011448-37	Chute
4		Chute insulation, part of item 3
5	1011448-38	Screw
6	1011448-39	Grommet
7	1011448-40	Flanged bushing
8	1011448-41	Cap screw
9	1011448-42	Vibration grommet
9a	1011448-43	Washer
10	1011448-44	Mounting plate only
11	9051610-01	Shelf, gear and evap asy
12	1011448-45	Drain
13	1011448-46	Drain plug
14	1011448-47	Thumb screw
15	1011448-48	Cover
16		Cover insulation, part of item 15

17	1011448-49	Support bracket, left
	1011448-50	Support bracket, right
18	1011448-18	Screw
19	1411448-51	Tube, reservoir to evap

\*Items 3,4,15 and 16 changed together on 9/25/13 with Serial Number 13091320014771.

Items 3,4,15 and 16 cannot be mixed with prior production. (Set)

Order Kit 101448-118 to get the set.

20	1011448-120	Plastic Splash Divider
----	-------------	------------------------



Service Parts

Reservoir, Water Sensor and Misc

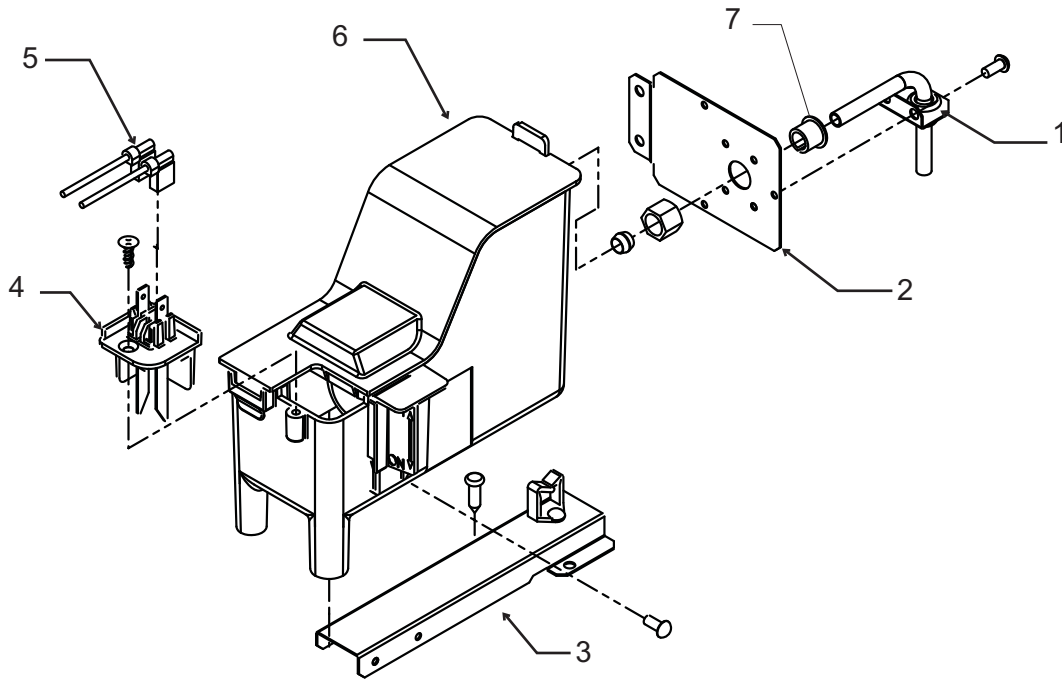

Item Number	Part Number	Description
1	1011448-52	Brace
2	1011148-53	Bracket
3	1011448-54	Reservoir mounting bracket
4	1011448-55	Water level sensor
5	1011448-56	Water sensor harness
6	1011448-57	Reservoir w/valve and cover
	1011448-116	Float valve only

Misc:

	1011448-59	12 pack of Pre-Mixed Squirt Bottle of Clear 1 scale remover
7	1011351-50	Bushing

Service Parts

Refrigeration

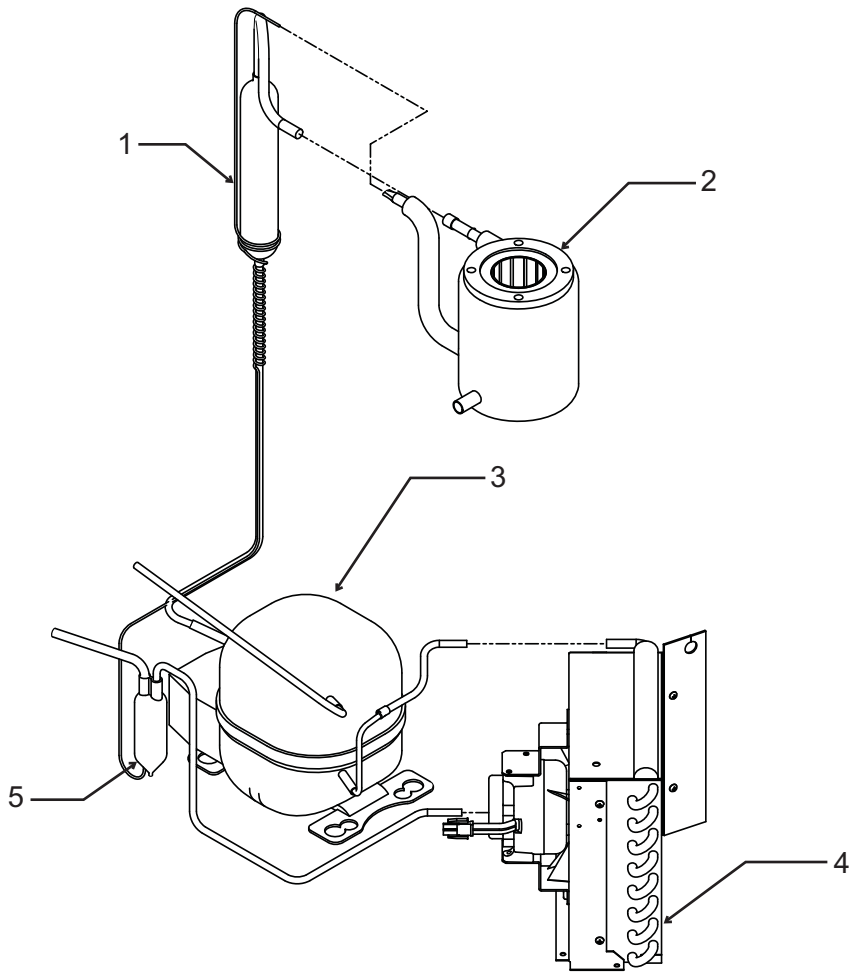

Item Number	Part Number	Description
1	1011448-61	Suction line w/cap tube
2	1011448-62	Evaporator
3	1011448-63	Compressor
Compressor includes overload, relay and drier		
3a	1011448-64	Overload
3b	1011448-65	Relay
4	1011448-66	Condenser
5	1011448-115	Dryer

Service Parts

Under Bin Parts

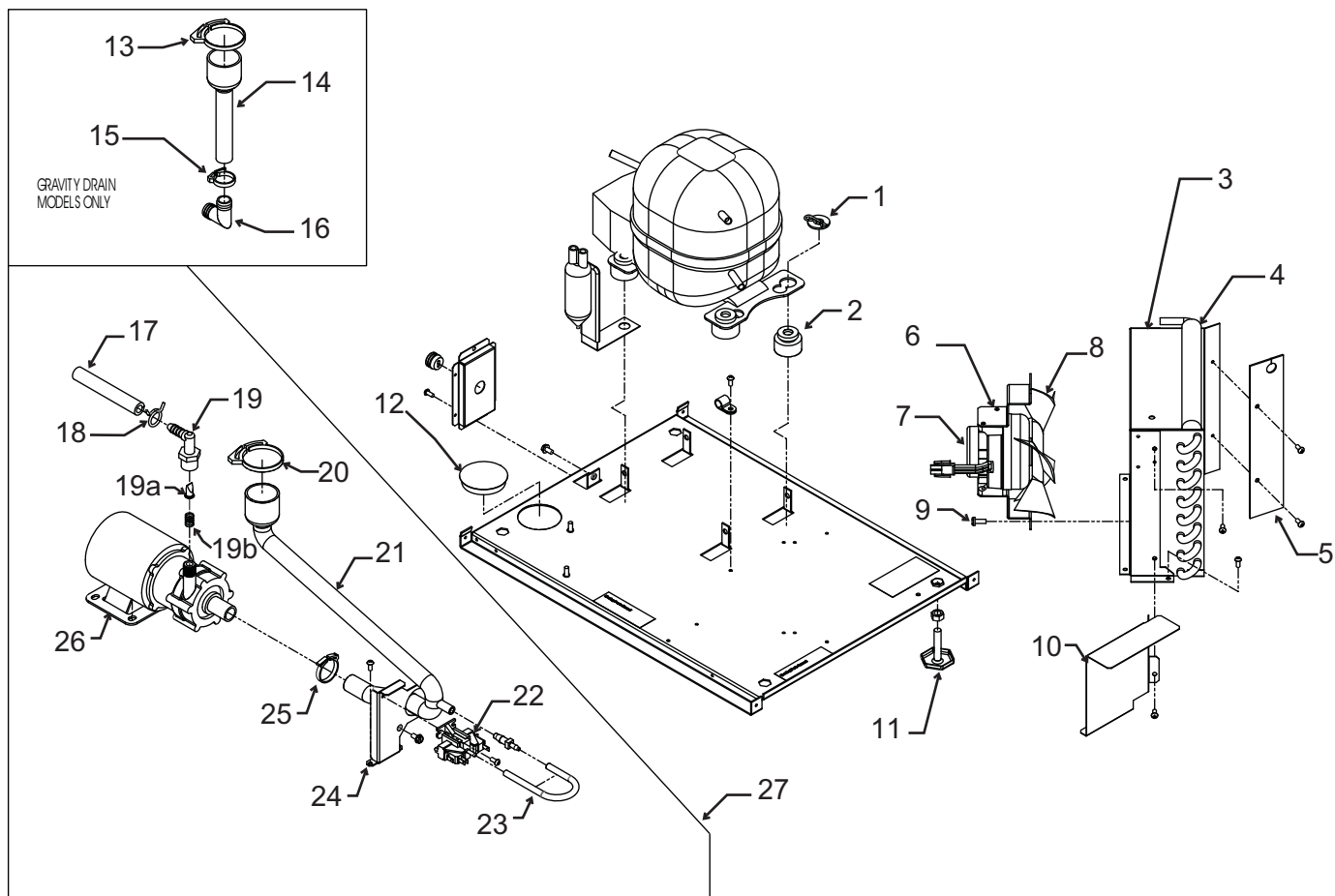

Item Number	Part Number	Description
1	1011448-68	Clip
1a	1011448-69	Washer
2	1011448-70	Grommet
3	1011448-71	Shroud
4	1011448-72	Gasket - order 1 & cut to fit
5	1011448-73	Air baffle
6	1011448-74	Fan motor bracket
7	1011448-75	Fan motor
8	1011448-76	Fan blade
9	1011448-77	Screw
10	1011448-78	Pump model rain shield
11	1011448-79	Leg leveler
12	1011448-80	Hole plug
13	1011448-81	Hose clamp
14	1011448-82	Drain hose
15	1011447-07	Hose clamp
16	1011448-83	Elbow
17	1011448-84	Discharge hose
18	1011448-85	Hose clamp
19	1011448-86	Elbow
19a	1011448-122	Check valve
19b	1011448-123	Spring
20	1011448-87	Hose clamp
21	1011448-88	Drain tube
22	1011448-89	Pressure switch
22a	1011448-129	Pressure harness
23	1011448-90	Switch hose
24	1011448-91	Switch bracket
25	1011448-81	Hose clamp
26	1011448-92	Pump & motor only
	KPU090	Pump kit
19b	1011448-123	Spring
19a	1011448-122	Check Valve
Not Shown	1011448-129	Pump Motor Harness

Service Parts

Ice Making Section

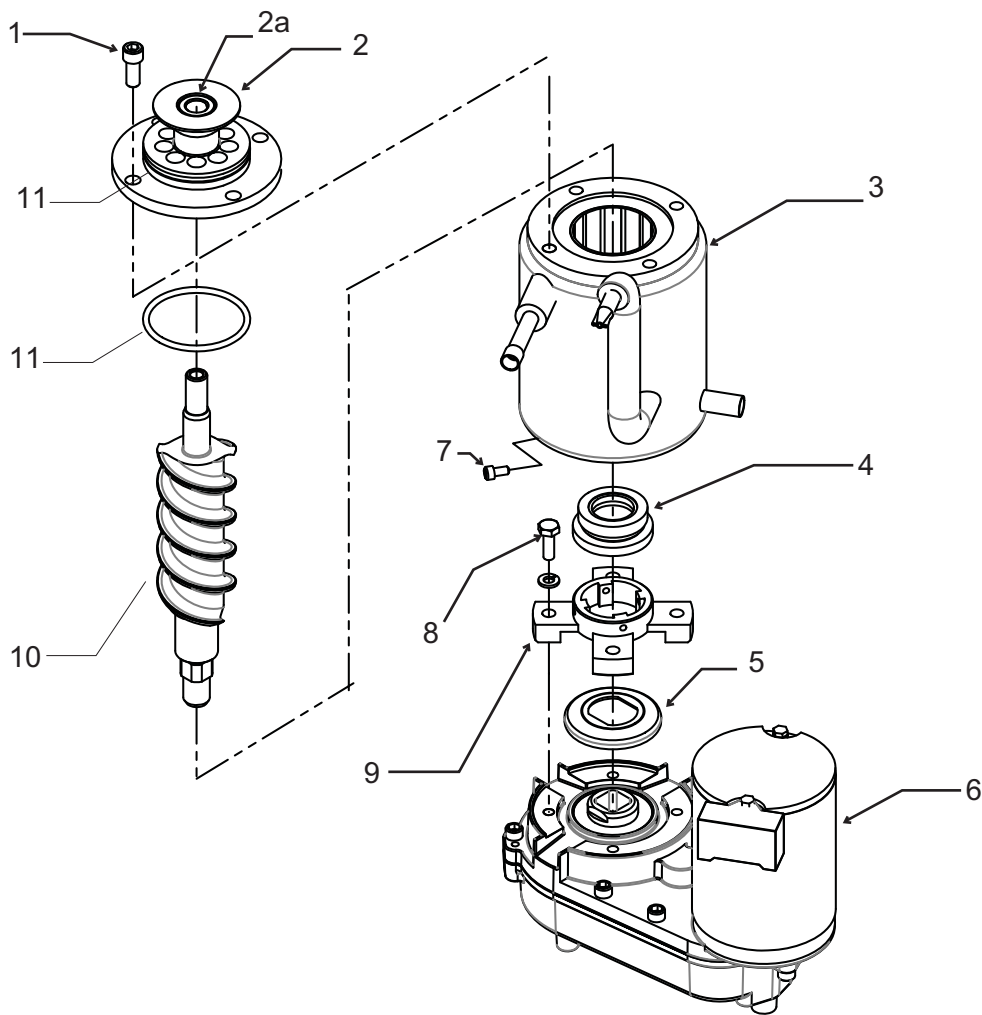

Item Number	Part Number	Description
1	1011380-44	Cap screw
2	1011448-93	Breaker w/bearing
2a	1011448-94	Bearing only
3	1011448-62	Evaporator
4	1011448-95	Water seal
5	1011448-96	Water shed
6	1011448-97	Gear reducer complete
6a	02-4580-22	Motor*
6b	02-4580-23	Capacitor*
7	1011448-100	Cap screw
8	1011448-101	Cap screw
9	1011448-102	Adapter
10	1011448-103	Auger
11	1011448-104	O-ring

\* Must connect wires correctly. See label on motor.

Service Parts

Control System

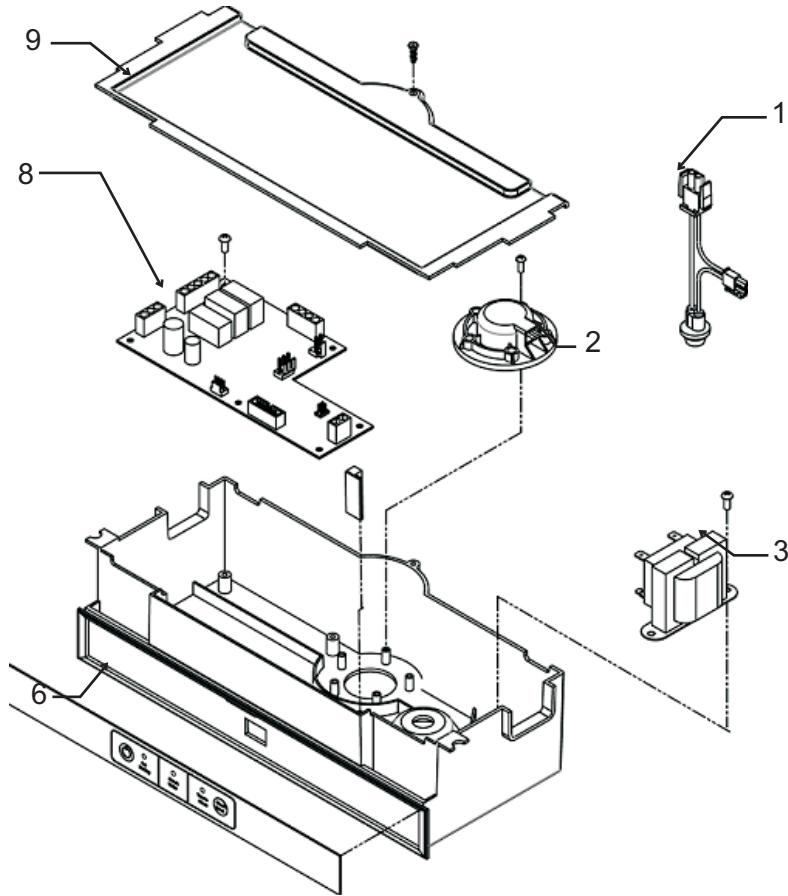

Item Number	Part Number	Description
1	NA	Harness, bin light
2	1011448-106	Ice level sensor
3	1011448-107	Transformer
6	1011448-108	Control panel
8	1011448-109	Controller
9	1011448-110	Cover
10	1011448-125	Control Box ( black)

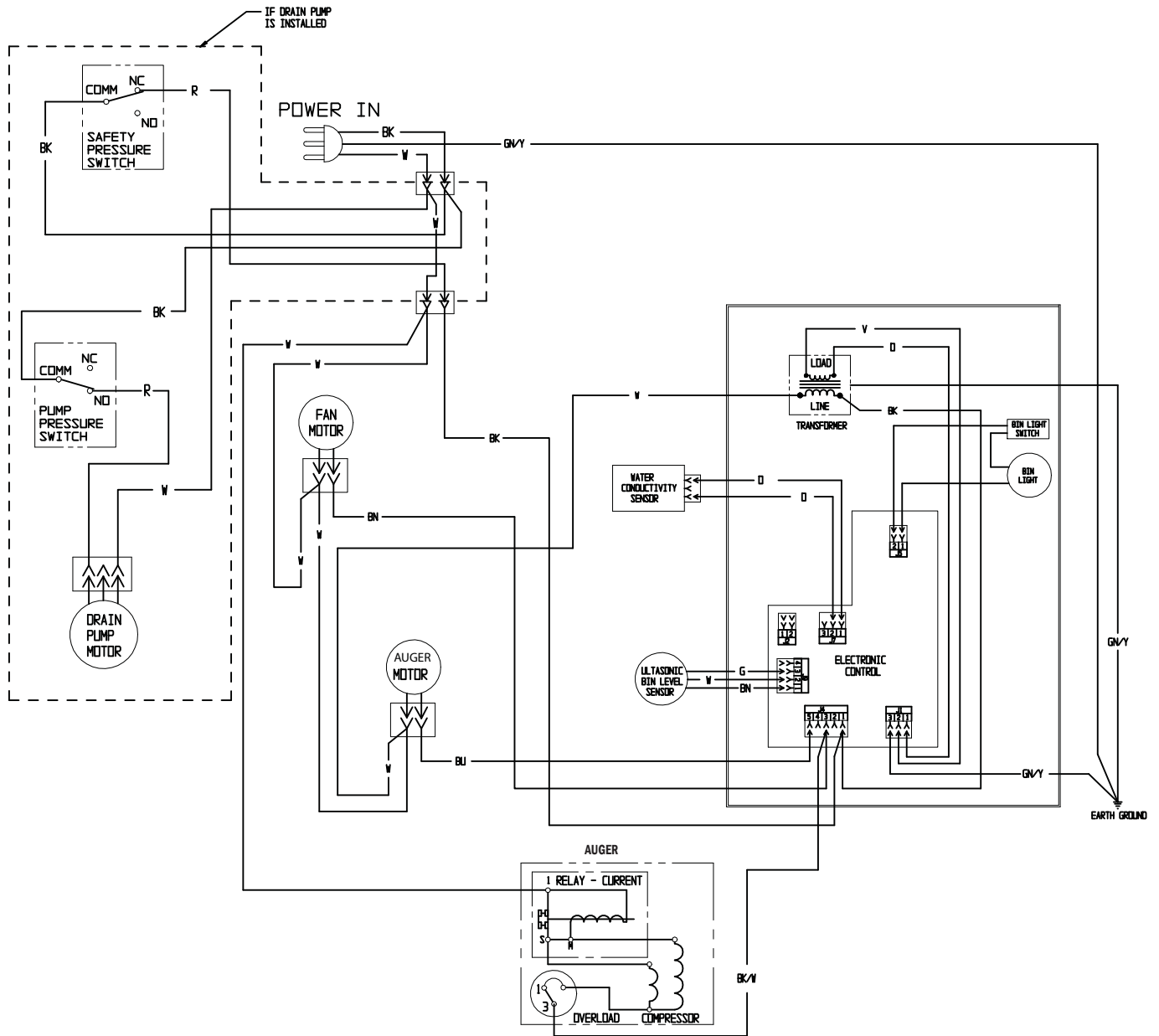

### Service Parts Schematic Diagram

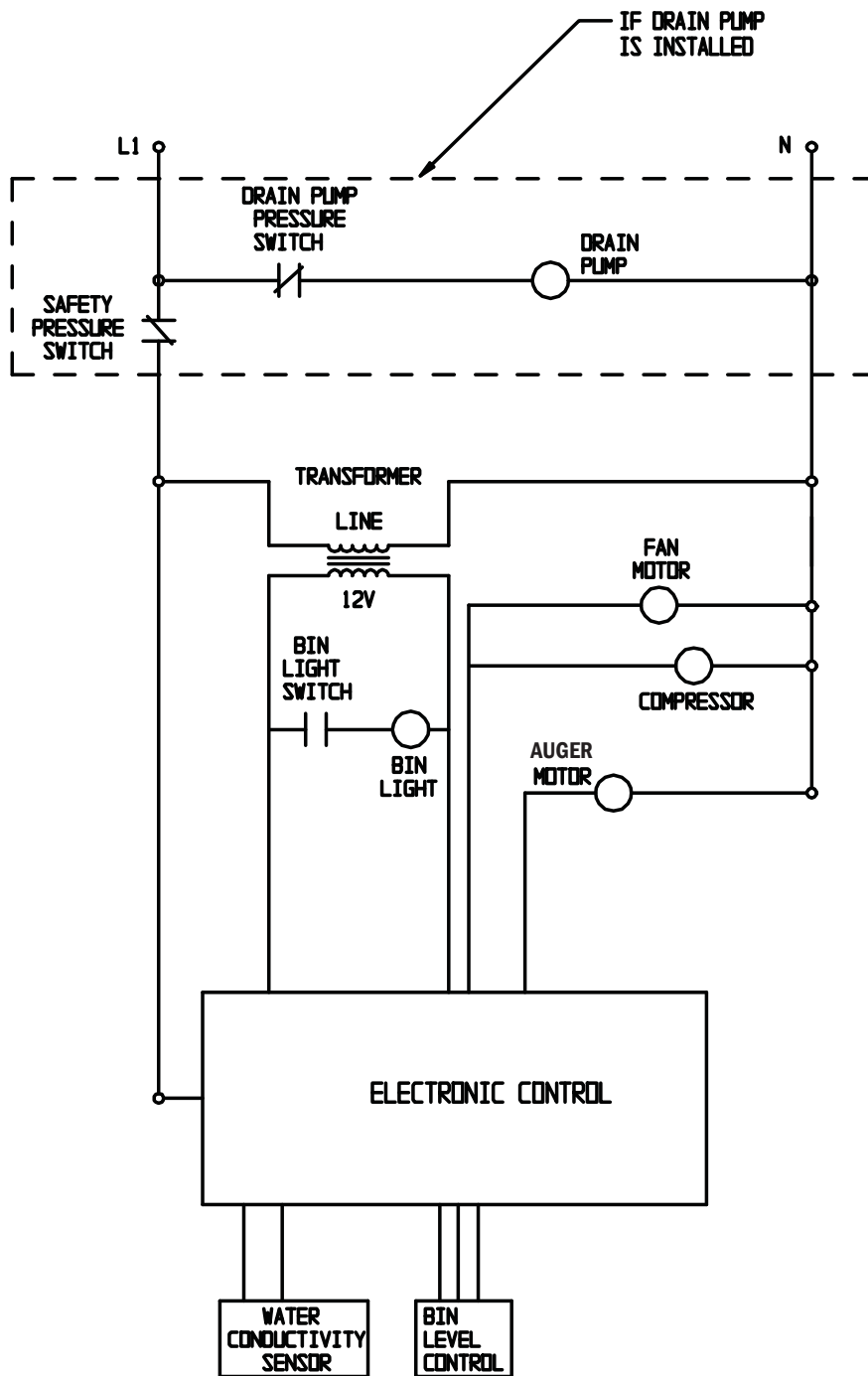

SWITCHES ON THIS UNIT  
SHOWN IN FREEZE CYCLE  
WITH DRAIN PUMP IN OPERATION  
AND BIN DOOR CLOSED

**Ice-O-Matic**